

Assembly guide:

MiKo-1



Version 1.1

Date: 14-10-2024



Revision:

REV	Date	Description
1	20-7-2024	First release
1.01	23-9-2024	See Revision document
1.1	14-10-2024	<ul style="list-style-type: none">• Updatet missing information<ul style="list-style-type: none">○ Firmware installation• Updated parts:<ul style="list-style-type: none">○ ROBOT_032○ ROBOT_010○ ROBOT_011○ ROBOT_029○ ROBOT_026• Created 2 new parts:<ul style="list-style-type: none">○ ROBOT_052, only needed for IO box with vacuum tool○ ROBOT_053, spacer for mounting the robot arm• Updated the assembly instructions• Added the modification drawing of the breakout board of the ESP32 to the appendix• Updated the BOM see BOM.slsx



Index

1: Introduction	4
2: Print files	5
3: BOM	19
4: Modifications parts.....	24
5: Schematic	25
6: Assembly instructions	26
7: Firmware installation	120
8: Appendix	123



1: Introduction

This document will describe how to assemble the Miko-1 robot arm. Because this is the first version of Miko-1, there may be some imperfections. We will try to resolve these as soon as possible. We apologize for any inconvenience you may encounter. If you find any mistakes in this document, please let us know by emailing info@mikobots.com.

Using the robot is at your own risk.

To ensure the safe operation of the robot arm, you need to have sufficient knowledge of electronics. If you are unsure how to proceed, please do not attempt it and ask a professional.

All measurements in this document are in millimeters (mm) or specified otherwise.

2: Print files

In this chapter you will find all the parts that you need to print for the Miko-1 robot arm. We recommend using PETG filament because it has a higher glass transition temperature than PLA and is still easy to print.

The total amount of PETG needed is approximately 3 kg. If you print it in the same color configuration, you will need 1.6 kg of red filament and 1.4 kg of black filament.

The general print settings that we have used for the parts are:

- Layer height: 0.2mm
- Walls: 3
- Infill: 20%

The tolerances used are as tight possible to achieve the best results. This means that sometimes you may need to use a little bit of force to assemble some parts. The given tolerance for certain parts, such as bearings, depends on the layer direction of the part. We have created a test part to check if your printer can print the parts with the given tolerances. If you encounter problems with the tolerance of any part, please let us know.

If you want access to the 3D files you will have to buy the digital files, or a kit.

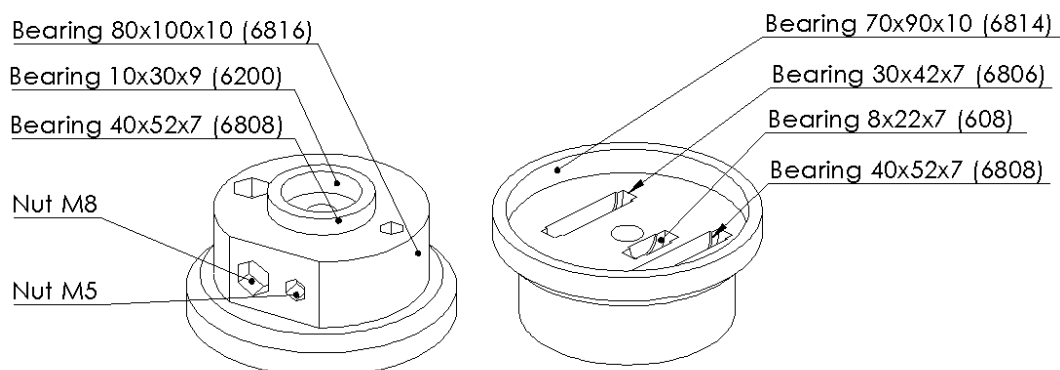



Art. name: ROBOT_001

Revision: 000

Quantity: 1

Infill: 20%

Walls: 3

Comments:

Colour: Black

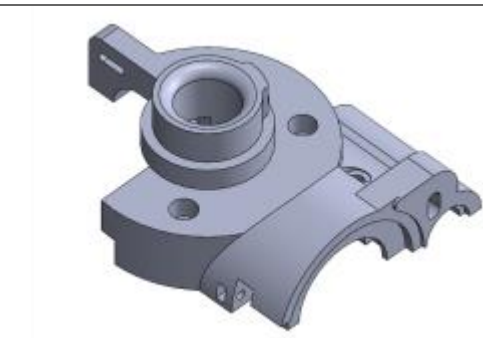

Art. name: ROBOT_002

Revision: 000

Quantity: 1

Infill: 20%

Walls: 3

Comments:

Colour: Black

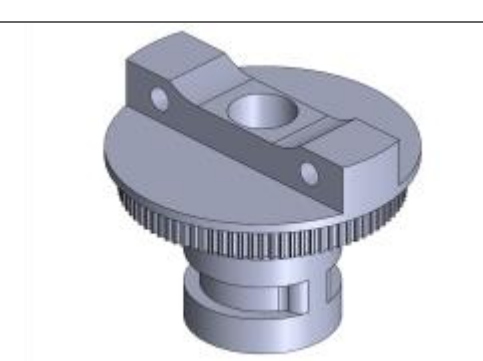

Art. name: ROBOT_003

Revision: 000

Quantity: 1

Infill: 20%

Walls: 3

Comments:

Colour: Black

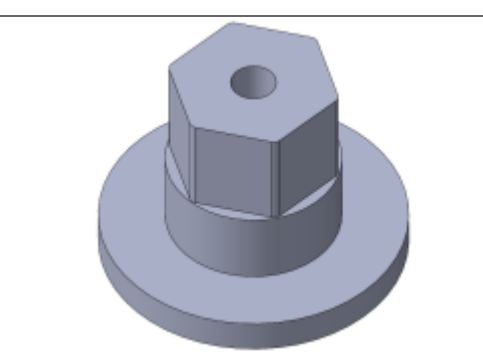

Art. name: ROBOT_004

Revision: 000

Quantity: 1

Infill: 20%

Walls: 3

Comments:

Colour: Black

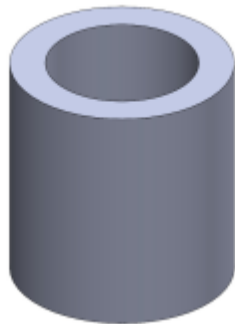

Art. name: ROBOT_005

Revision: 000

Quantity: 1

Infill: 20%

Walls: 3

Comments:

Colour: Black

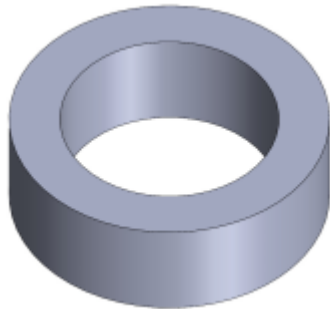

Art. name: ROBOT_006

Revision: 000

Quantity: 1

Infill: 20%

Walls: 3

Comments:

Colour: Black



Art. name: ROBOT_007

Revision: 000

Quantity: 1

Infill: 20%

Walls: 3

Comments:

Colour: Red



Art. name: ROBOT_008

Revision: 000

Quantity: 1

Infill: 20%

Walls: 3

Comments:

Colour: Red



Art. name: ROBOT_009

Revision: 000

Quantity: 1

Infill: 20%

Walls: 3

Comments:

Colour: Red

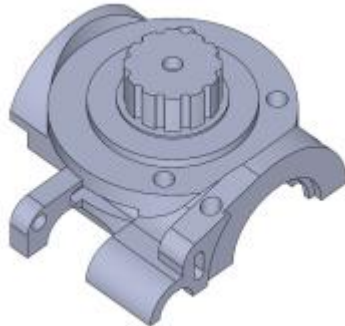

Art. name: ROBOT_010

Revision: 001

Quantity: 1

Infill: 20%

Walls: 3

Comments:

Colour: Red

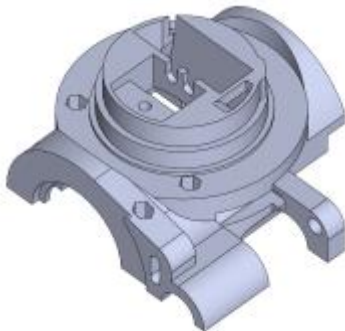

Art. name: ROBOT_011

Revision: 001

Quantity: 1

Infill: 20%

Walls: 3

Comments:

Colour: Red

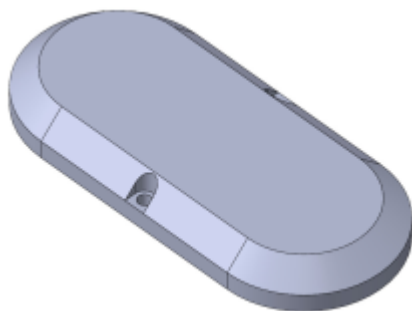

Art. name: ROBOT_012

Revision: 000

Quantity: 1

Infill: 20%

Walls: 3

Comments:

Colour: Red

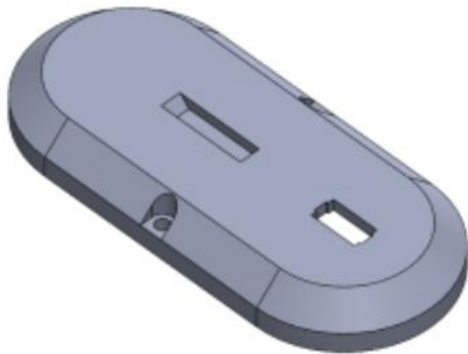

Art. name: ROBOT_013

Revision: 000

Quantity: 1

Infill: 20%

Walls: 3

Comments:

Colour: Red

When using IO box use the part ROBOT_013_IO

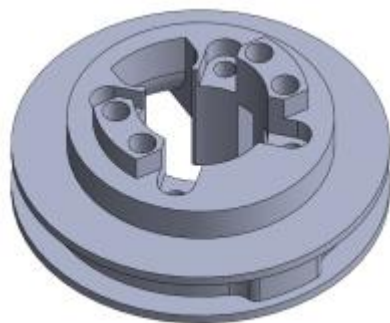

Art. name: ROBOT_014

Revision: 000

Quantity: 1

Infill: 20%

Walls: 3

Comments:

Colour: Red

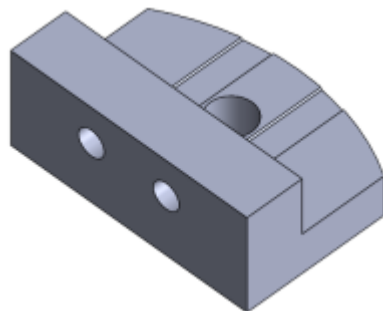

Art. name: ROBOT_015

Revision: 000

Quantity: 1

Infill: 20%

Walls: 3

Comments:

Colour: Black

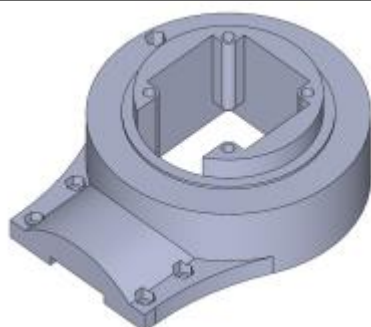

Art. name: ROBOT_016

Revision: 000

Quantity: 1

Infill: 20%

Walls: 3

Comments:

Colour: Black

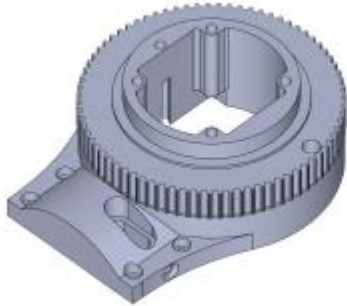

Art. name: ROBOT_017

Revision: 001

Quantity: 1

Infill: 20%

Walls: 3

Comments:
Colour: Black

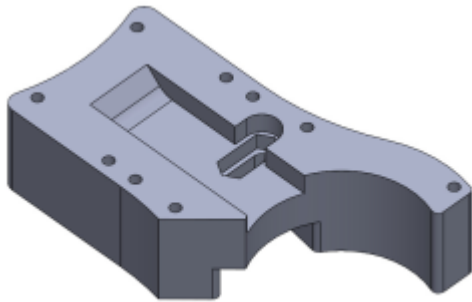

Art. name: ROBOT_018

Revision: 000

Quantity: 1

Infill: 20%

Walls: 3

Comments:
Colour: Black

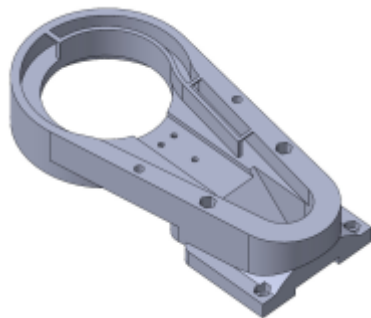

Art. name: ROBOT_019

Revision: 000

Quantity: 1

Infill: 20%

Walls: 3

Comments:
Colour: Black



Art. name: ROBOT_020

Revision: 000

Quantity: 1

Infill: 20%

Walls: 3

Comments:
Colour: Black

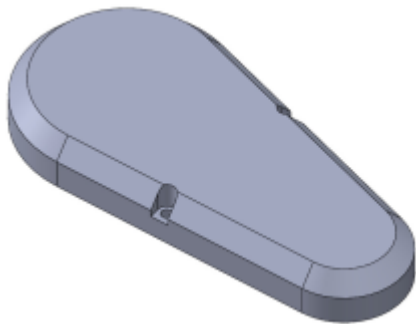

Art. name: ROBOT_021

Revision: 000

Quantity: 1

Infill: 20%

Walls: 3

Comments:
Colour: Black

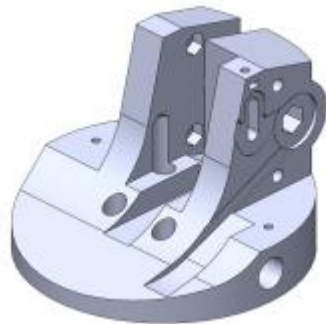

Art. name: ROBOT_022

Revision: 000

Quantity: 1

Infill: 20%

Walls: 3

Colour: Red

If you have ordered pulley with a width of 25 mm you should use part ROBOT_050

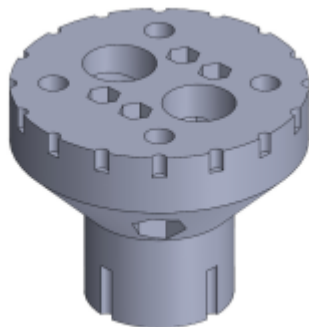

Art. name: ROBOT_023

Revision: 000

Quantity: 1

Infill: 20%

Walls: 3

Colour: Black/ Red



Art. name: ROBOT_024

Revision: 000

Quantity: 1

Infill: 20%

Walls: 3

Comments:
Colour: Black



Art. name: ROBOT_025

Revision: 000

Quantity: 1

Infill: 20%

Walls: 3

Comments:

Colour: Red

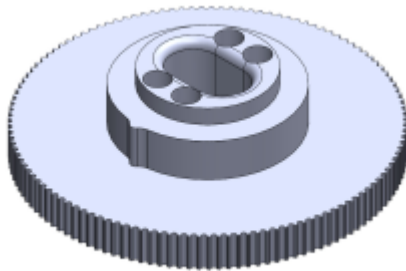

Art. name: ROBOT_026

Revision: 001

Quantity: 1

Infill: 20%

Walls: 3

Comments:

Colour: Black/ Red

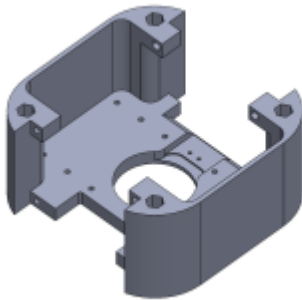

Art. name: ROBOT_027

Revision: 000

Quantity: 1

Infill: 20%

Walls: 3

Comments:

Colour: Black



Art. name: ROBOT_028

Revision: 000

Quantity: 1

Infill: 20%

Walls: 3

Comments:

Colour: Red

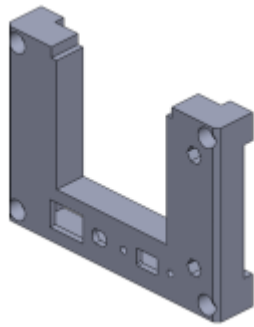

Art. name: ROBOT_029

Revision: 001

Quantity: 1

Infill: 20%

Walls: 3

Comments:
Colour: Black

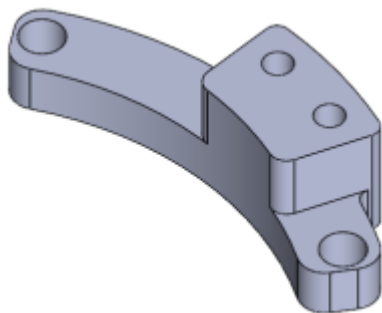

Art. name: ROBOT_030

Revision: 000

Quantity: 1

Infill: 20%

Walls: 3

Comments:
Colour: Black



Art. name: ROBOT_031

Revision: 000

Quantity: 1

Infill: 20%

Walls: 3

Comments:
Colour: Red

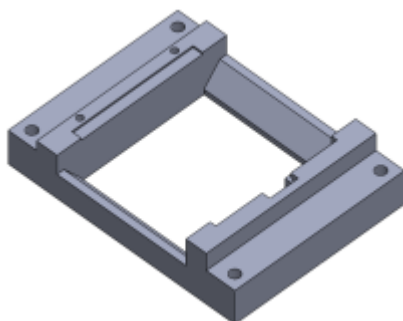

Art. name: ROBOT_032

Revision: 001

Quantity: 1

Infill: 20%

Walls: 3

Comments:
Colour: Black



Art. name: ROBOT_033

Revision: 000

Quantity: 1

Infill: 20%

Walls: 3

Comments:

Colour: Black



Art. name: ROBOT_034

Revision: 000

Quantity: 1

Infill: 20%

Walls: 3

Comments:

Colour: Black

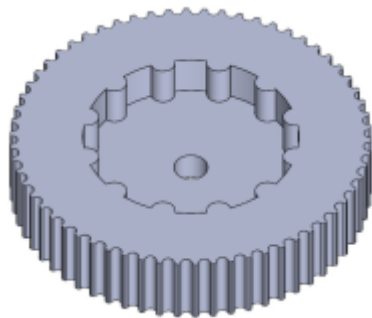

Art. name: ROBOT_035

Revision: 000

Quantity: 1

Infill: 20%

Walls: 3

Comments:

Colour: Black

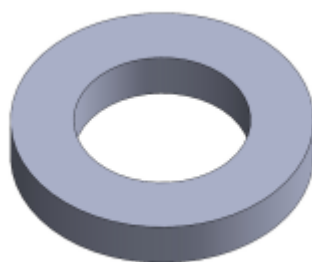

Art. name: ROBOT_036

Revision: 000

Quantity: 1

Infill: 20%

Walls: 3

Comments:

Colour: Black/ Red

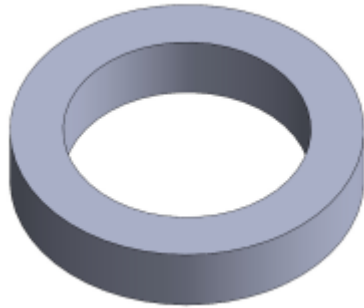

Art. name: ROBOT_037

Revision: 000

Quantity: 1

Infill: 20%

Walls: 3

Comments:

Colour: Black/ Red

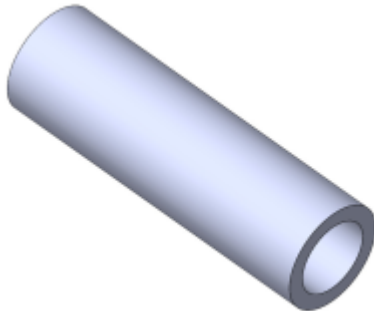

Art. name: ROBOT_038

Revision: 000

Quantity: 1

Infill: 20%

Walls: 3

Comments:

Colour: Black/ Red

If you have ordered pulley with a width of 25 mm you should use part ROBOT_051



Art. name: ROBOT_039

Revision: 000

Quantity: 1

Infill: 20%

Walls: 3

Comments:

Colour: Black/ Red

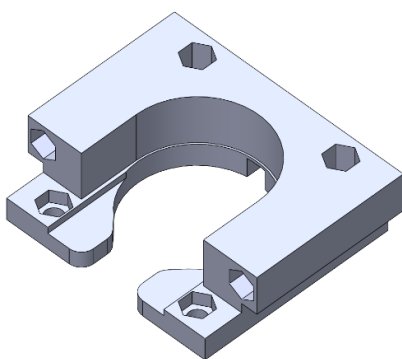

Art. name: ROBOT_040

Revision: 000

Quantity: 1

Infill: 20%

Walls: 3

Comments:

Colour: Red

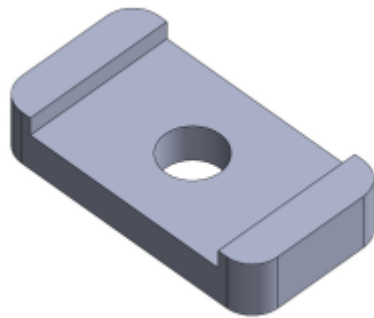

Art. name: ROBOT_041

Revision: 000

Quantity: 3

Infill: 20%

Walls: 3

Comments:

Colour: Black

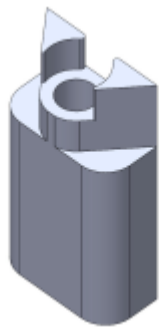

Art. name: ROBOT_042

Revision: 000

Quantity: 1

Infill: 20%

Walls: 3

Comments:

Colour: Black

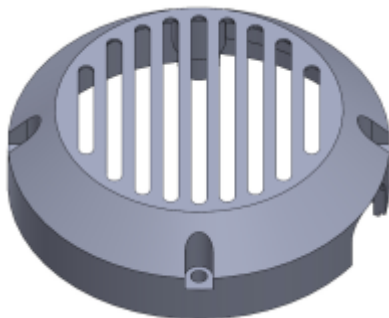

Art. name: ROBOT_043

Revision: 000

Quantity: 1

Infill: 20%

Walls: 3

Comments:

Colour: Black

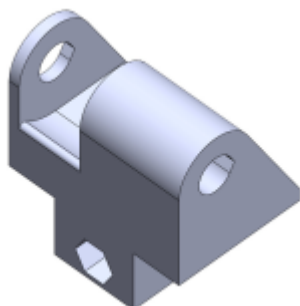

Art. name: ROBOT_044

Revision: 000

Quantity: 1

Infill: 20%

Walls: 3

Comments:

Colour: Black

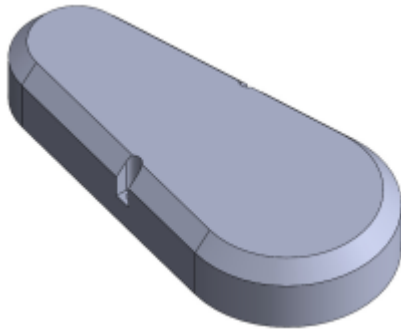

Art. name: ROBOT_045

Revision: 000

Quantity: 1

Infill: 20%

Walls: 3

Comments:

Colour: Black

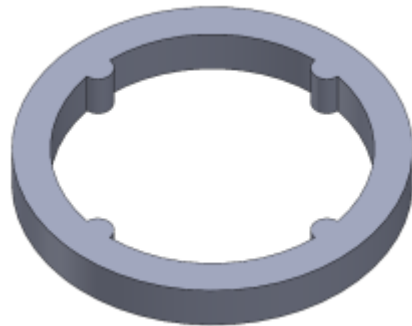

Art. name: ROBOT_046

Revision: 000

Quantity: 1

Infill: 20%

Walls: 3

Comments:

Colour: Black

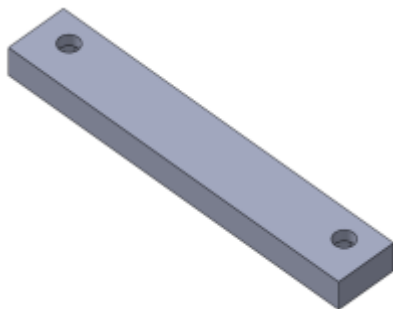

Art. name: ROBOT_048

Revision: 000

Quantity: 1

Infill: 20%

Walls: 3

Comments:

Colour: Black



Art. name: ROBOT_049

Revision: 000

Quantity: 1

Infill: 20%

Walls: 3

Comments:

Colour: Black/ Red



Art. name: ROBOT_052

Revision: 000

Quantity: 1

Infill: 20%

Walls: 3

Comments:

Colour: Black/ Red

Only needed if you are using the IO box with vacuum pump

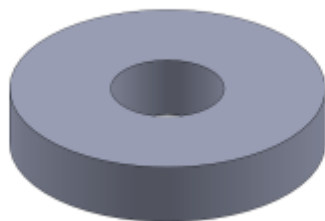

Art. name: ROBOT_053

Revision: 000

Quantity: 1

Infill: 20%

Walls: 3

Comments:

Colour: Black/ Red

Spacer for mounting the robot to a table or plateau



3: BOM

In this chapter, you will find all the parts that you need to buy for the robot arm. If you see any mistakes or have any questions, you can email us at info@mikobots.com or ask the question in the Discord server. We have tried to provide a link to a shop for each component, but these links could change or become invalid. We will try to update the links regularly.

Please remember that you are solely responsible for ensuring the parts meet the safety requirements for your country. If you have bought the kit without motors and drivers you will have to buy the kit on stepper online ([link](#)).

Besides the parts in the BOM you also need some tyrap and some heat shrink tubing.

Before ordering the parts, it's recommended to first read the whole document.



Axis

Name	QTY.	Description	Shop
AXIS_01	1	Axis Ø8 L65	
AXIS_02	1	Axis Ø8 L85	
AXIS_03	1	Axis Ø10 L132	
AXIS_04	1	Axis Ø8 L145	
AXIS_05	1	Axis Ø10 L70	
AXIS_06	1	Axis Ø8 L40	

Bearings

Name	QTY.	Description	Shop
BEARING_01	26	Bearing 5x14x5 (605)	Link
BEARING_02	4	Bearing 10x30x9 (6200)	Link
BEARING_03	15	Bearing 8x22x7 (608)	Link
BEARING_04	6	Bearing 40x52x7 (6808)	Link
BEARING_05	1	Bearing 70x90x10 (6814)	Link
BEARING_06	3	Bearing 80x100x10 (6816)	Link
BEARING_07	2	Bearing 30x42x7 (6806)	Link
BEARING_08	4	Axial bearing 50x70x5 (AXK5070 2AS)	Link
BEARING_09	2	Axial bearing Ø52x35x4 (AXK3552 2AS)	Link
BEARING_10	1	Axial bearing 120x155x6 (AXK120155 2AS)	Link
BEARING_11	1	Axial bearing 20x35x4 (AXK2035 2AS)	Link

Coupling

Name	QTY.	Description	Shop
COUPLING_01 *	1	Coupler Ø 8 - Ø 5	Link
COUPLING_02 *	1	Coupler Ø 8 - Ø 8	Link

Electronics

Name	QTY.	Description	Shop
ELECTRONICS_001	6	Micro Limit Switch (Roller Lever)	Link
ELECTRONICS_002	1	On Off switch	Link
ELECTRONICS_003	1	Breakout board esp32	Link
ELECTRONICS_004	1	ESP32 38 pin	Link
ELECTRONICS_005	2	5,5 x 2,1 mm jack	Link
ELECTRONICS_007	1	USB connector 2 pin	Link
ELECTRONICS_008	1	micro usb to cable 90 degrees Down	Link
ELECTRONICS_009	1	24V to 5V DC converter	Link
ELECTRONICS_014	1	Power supply 24V 6A, jack 5,5x2,1	
ELECTRONICS_015	1	Micro usb cable 1.5m	
ELECTRONICS_020	2	Wago 221-415	Link
ELECTRONICS_021	1	Wago 221-2411	Link
ELECTRONICS_022	3	15EDGRK 3.81 03P Male and female screw	Link
ELECTRONICS_023	5	15EDGRK 3.81 04P Male and female screw	Link
ELECTRONICS_024	5	15EDGRK 3.81 02P Male and female screw	Link
ELECTRONICS_025	2	Terminal FDD1.25-187, 0.5-1mm ² , 4.8x0.5	Link

Drivers

Name	QTY.	Description	Shop
DRIVER_01 *	3	Stepper motor driver DM332T	Link
DRIVER_02 *	3	Stepper motor driver DM320T	Link

Gearbox

Name	QTY.	Description	Shop
GEARBOX_01 *	1	Gearbox Nema 17 1:5	Link

Cables

Name	QTY.	Description	Shop
CABLE_01	5 m	Cable 2 wire, 22 AWG/ 0.34 mm ²	Link
CABLE_02	1	3P Dupont cable male 100cm	Link
CABLE_03 **	3	Nema 17 cable 50 cm	Link
CABLE_04	4,5 m	Cable 4P 22 awg	Link
CABLE_05 ***	1 m	Cable 0,75 mm ² , 18 AWG, blue	
CABLE_06 ***	1 m	Cable 0,75 mm ² , 18 AWG, white	



Fasteners

Name	QTY.	Description	Shop
DIN 912 M3 x 10	14	Hexagon socket Head Cap Screws M3x10	Link
DIN 912 M3 x 16	15	Hexagon socket Head Cap Screws M3x16	Link
DIN 912 M4 x 16	14	Hexagon socket Head Cap Screws M4x16	Link
DIN 912 M4 x 25	4	Hexagon socket Head Cap Screws M4x25	Link
DIN 912 M5 x 20	22	Hexagon socket Head Cap Screws M5x20	Link
DIN 912 M5 x 35	31	Hexagon socket Head Cap Screws M5x35	Link
DIN 912 M5 x 60	36	Hexagon socket Head Cap Screws M5x60	Link
DIN 912 M8 x 45	15	Hexagon socket Head Cap Screws M8x45	Link
DIN 912 M8 x 80	4	Hexagon socket Head Cap Screws M8x80	Link
DIN 913 M5 x 35	4	Set screw M5 x 35	Link
DIN 125 M3	8	Washer M3	Link
DIN 125 M5	11	Washer M5	Link
DIN 125 M8	5	Washer M8	Link
ISO 4032 M3	17	Hexagon regular nut M3	Link
ISO 4032 M4	14	Hexagon regular nut M4	Link
ISO 4032 M5	94	Hexagon regular nut M5	Link
ISO 4032 M8	11	Hexagon regular nut M8	Link
DIN 6334 M8	4	Hexagon coupling nut M8	Link

Motors

Name	QTY.	Description	Shop
MOTOR_01 *	2	Stepper motor Nema 17 L38	Link
MOTOR_02 *	2	Stepper motor Nema 23 L76	Link
MOTOR_03 *	1	Stepper motor Nema23 L56	Link
MOTOR_04 *	1	Stepper motor Nema 17 L48	Link



Belts

Name	QTY.	Description	Shop
BELT_01	1	Timing belt GT2 L200 W6	Link
BELT_02	1	Timing belt GT2 L158 W6	Link
BELT_03	1	Timing belt HTD 3M 294 W10	Link
BELT_04	1	Timing belt HTD5M L435 W15	Link
BELT_05	1	Timing belt HTD3M L393 W10	Link
BELT_06	1	Timing belt HTD5M L500 W15	Link
BELT_07	1	Timing belt HTD3M L345 W10	Link
BELT_08	1	Timing belt HTD3M L420 W10	Link
BELT_09	1	Timing belt HTD3M L426 W10	Link

Pulley

Name	QTY.	Description	Shop
PULLEY_01	2	Pulley GT2 20T W6 B8	Link
PULLEY_02	1	Pulley GT2 20T W6 B5	Link
PULLEY_03	2	Pulley HTD3M 16t W10 B8	Link
PULLEY_04	1	Pulley HTD3M 90t W10 B10	Link
PULLEY_05	1	Pulley HTD3M 60t W10 B10	Link
PULLEY_06	2	Pulley HTD5M 15T W15 B10	Link
PULLEY_07	3	Pulley HTD3M 12T W10 B6.35	Link

* You can buy this as a kit on [stepperonline](#)

** Included with the stepper motor if you buy it from [stepperonline](#)

*** Make sure the cable can handle 6A; otherwise, choose a thicker cable

4: Modifications parts

Some parts need some modifications, you can find the drawings of the modifications in the appendix. This includes the modifications for the following parts:

- Axis
- Breakout board (not always necessary check if you can plug in the USB connector before modifying the breakout board, see picture below)



5: Schematic and wiring

In this chapter, you will find all the information regarding the schematic and electronics of the robot arm.

Please remember that you are working with electronics, and even though the robot arm operates at only 24V, there are still potential dangers. Incorrect wiring or mishandling of components can lead to short circuits, electric shocks, or damage to the robot arm and its parts. Always double-check your connections and follow safety guidelines. If you are not confident in your knowledge of electronics, please seek assistance from a professional to ensure safe assembly and operation.

You can find the schematic in the appendix.

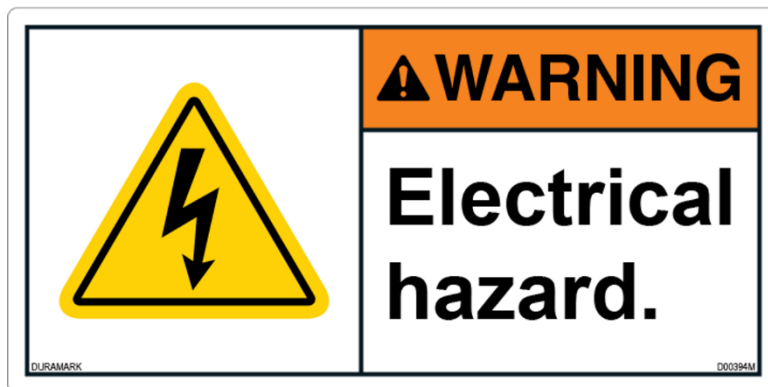



6: Assembly instructions

The instructions are written with care to include every step of the assembly process.

Step 1:

Items	QTY	Description
ROBOT_001	1	
ROBOT_005	1	
ROBOT_006	1	
BEARING_03	2	Bearing 8x22x7 (608)
PULLEY_01	2	Pulley GT2 20T W6 B8
AXIS_02	2	Axis Ø8 L85

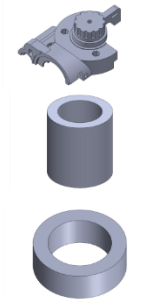

Instruction:

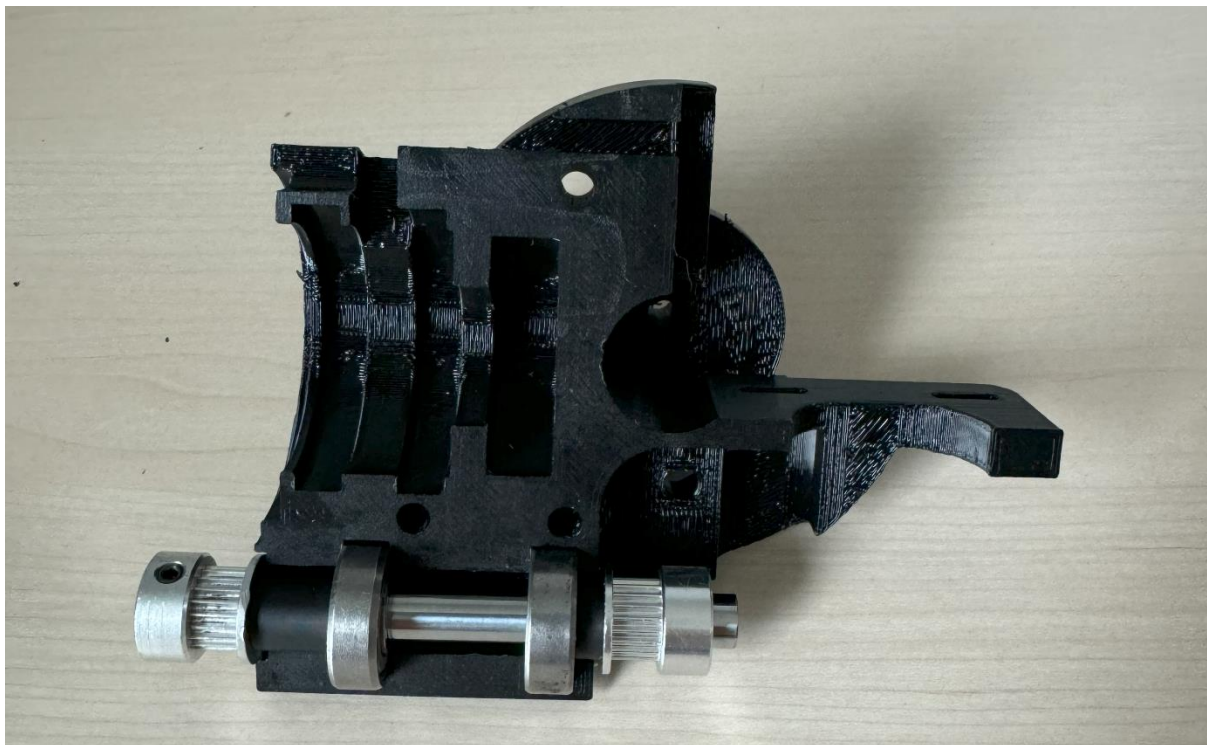

Step 2:

Items	QTY	Description
ROBOT_003	1	
ROBOT_004	1	
BEARING_07	2	Bearing 30x42x7 (6806)
BEARING_09	1	Axial bearing Ø52x35x4 (AXK3552 2AS)
BEARING_11	1	Axial bearing 20x35x4 (AXK2035 2AS)
DIN 912 M5 x 35	1	Hexagon socket Head Cap Screws M5x35
ISO 4032 M5	1	Hexagon regular nut M5

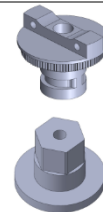

Instruction:

Do not tighten the M5 bolt yet.

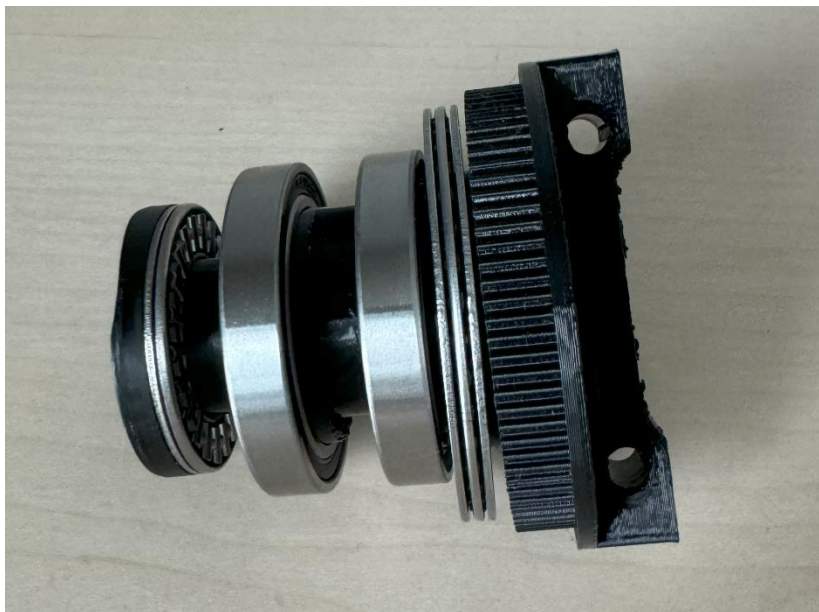

Step 3:

Items	QTY	Description
ISO 4032 M5	1	Hexagon regular nut M5

Instruction:

Insert the assembly from Step 2 into part ROBOT_001, and then insert the M5 nut into part ROBOT_001.

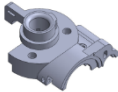

Step 4:

Items	QTY	Description
ROBOT_002	1	
DIN 912 M5 x 35	3	Hexagon socket Head Cap Screws M5x35
ISO 4032 M5	3	Hexagon regular nut M5

Instruction:

Tighten the M5 bolt assembled in Step 2. Ensure that the assembly can still turn properly.

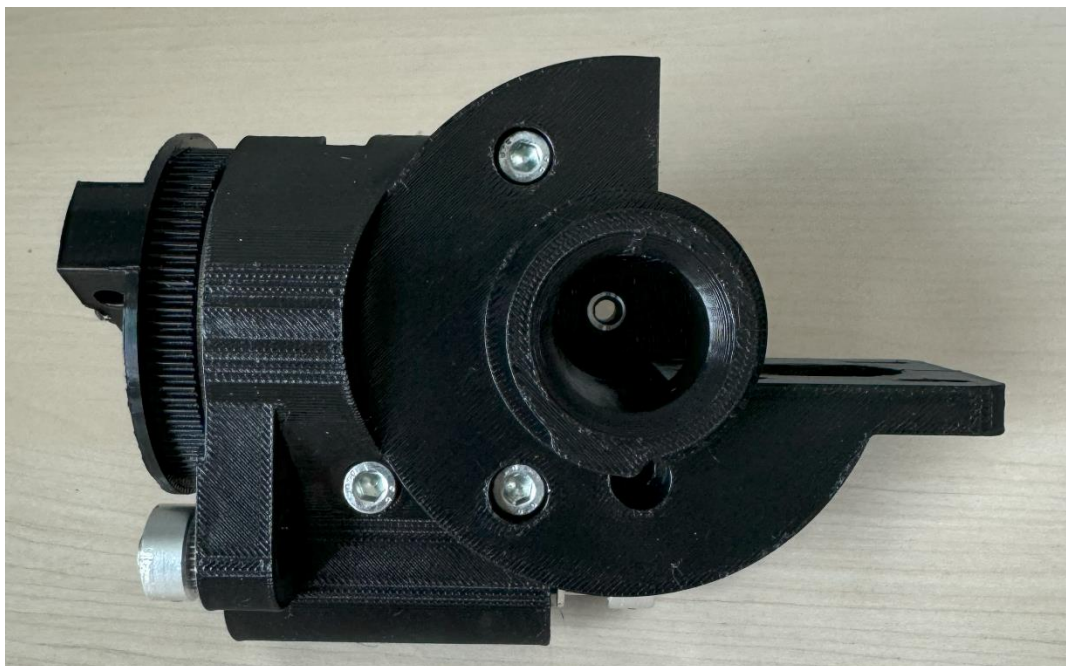

Step 5:

Items	QTY	Description
ISO 4032 M5	2	Hexagon regular nut M5
DIN 125 M5	2	Washer M5
DIN 912 M5 x 20	2	Hexagon socket Head Cap Screws M5x20
BEARING_01	2	Bearing 5x14x5 (605)
BELT_01	1	Timing belt GT2 L200 W6

Instruction:

First, position the belt in place. Next, install the bearings. Ensure that you place the washer behind the bearing, against the 3D-printed part. Tension the belt by moving the bearings toward each other.



Step 6:

Items	QTY	Description
LIM_SWITCH_06	1	See appendix, for the limit switches
DIN 912 M3 x 16	2	Hexagon socket Head Cap Screws M3x16
ISO 4032 M3	2	Hexagon regular nut M3

Instruction:

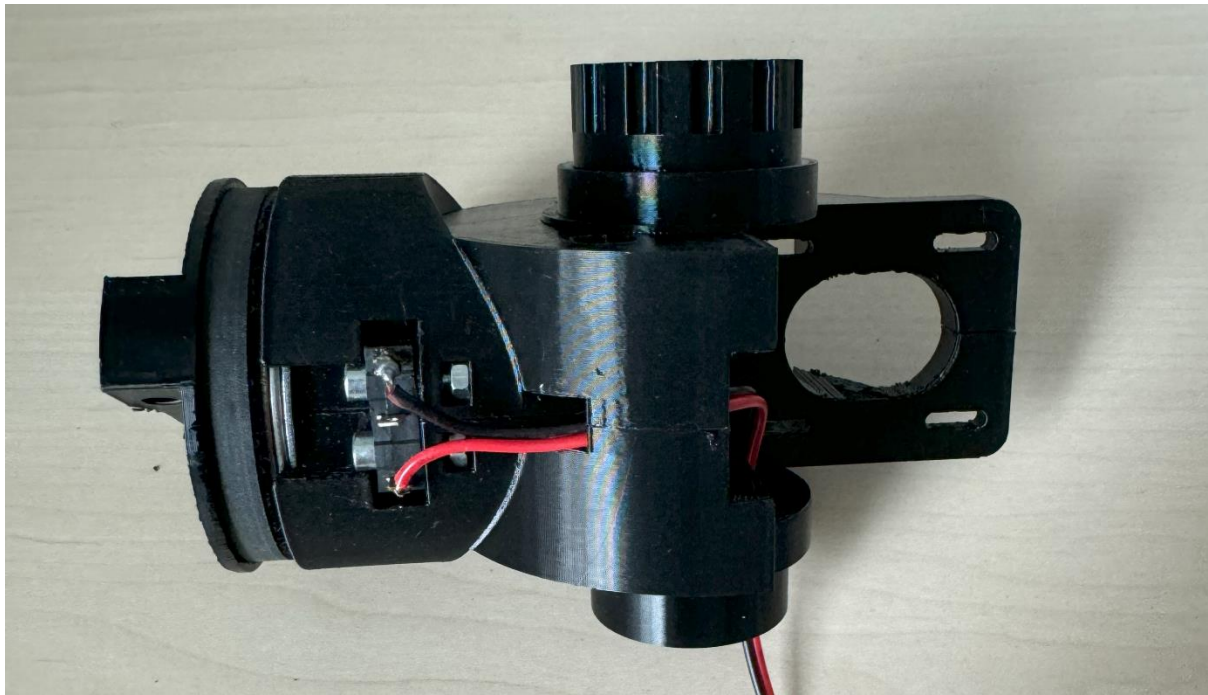

Step 7:

Items	QTY	Description
BELT_02	1	Timing belt GT2 L158 W6
DIN 912 M5 x 35	1	Hexagon socket Head Cap Screws M5x35
ISO 4032 M5	1	Hexagon regular nut M5
DIN 125 M5	1	Washer M5
BEARING_01	4	Bearing 5x14x5 (605)

Instruction:

In the middle, after the two bearings, mount the M5 washer. Ensure that the smooth side of the belt is facing the bearings. After tightening the M5 bolt, check if the bearings still turn easily. If they don't, slightly loosen the bolt.

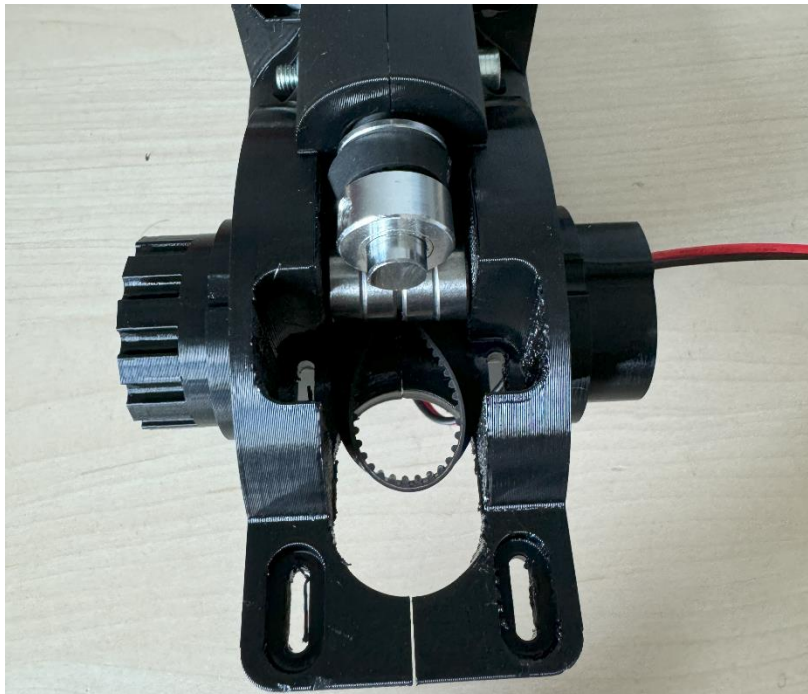

Step 8:

Items	QTY	Description
MOTOR_01	1	Stepper motor Nema 17 L38
PULLEY_02	1	Pulley GT2 20T W6 B5
CALBE_03	1	Nema 17 cable 50 cm
DIN 912 M3 x 10	4	Hexagon socket Head Cap Screws M3x10
DIN 125 M3	4	Washer M3

Instruction:

First, connect the wire to the motor. Next, install the pulley onto the motor shaft (see picture). Finally, mount the motor to the rest of the assembly.

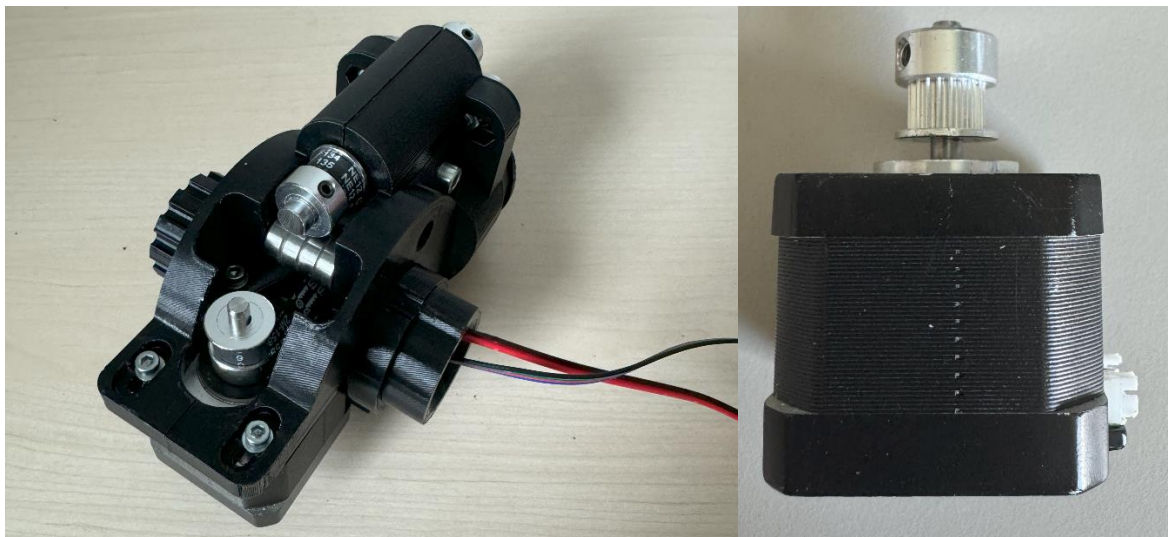

Step 9:

Items	QTY	Description
ROBOT_009	1	
BEARING_03	2	Bearing 8x22x7 (608)

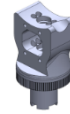

Instruction:

Insert the bearings in the part.



Step 10:

Items	QTY	Description
MOTOR_01	1	Stepper motor Nema 17 L38
GEARBOX_01	1	Gearbox Nema 17 1:5
COUPLING_02	1	Coupler $\varnothing 8 - \varnothing 8$

Instruction:

Use the M3 bolt delivered with the gearbox, to mount the gearbox to the motor

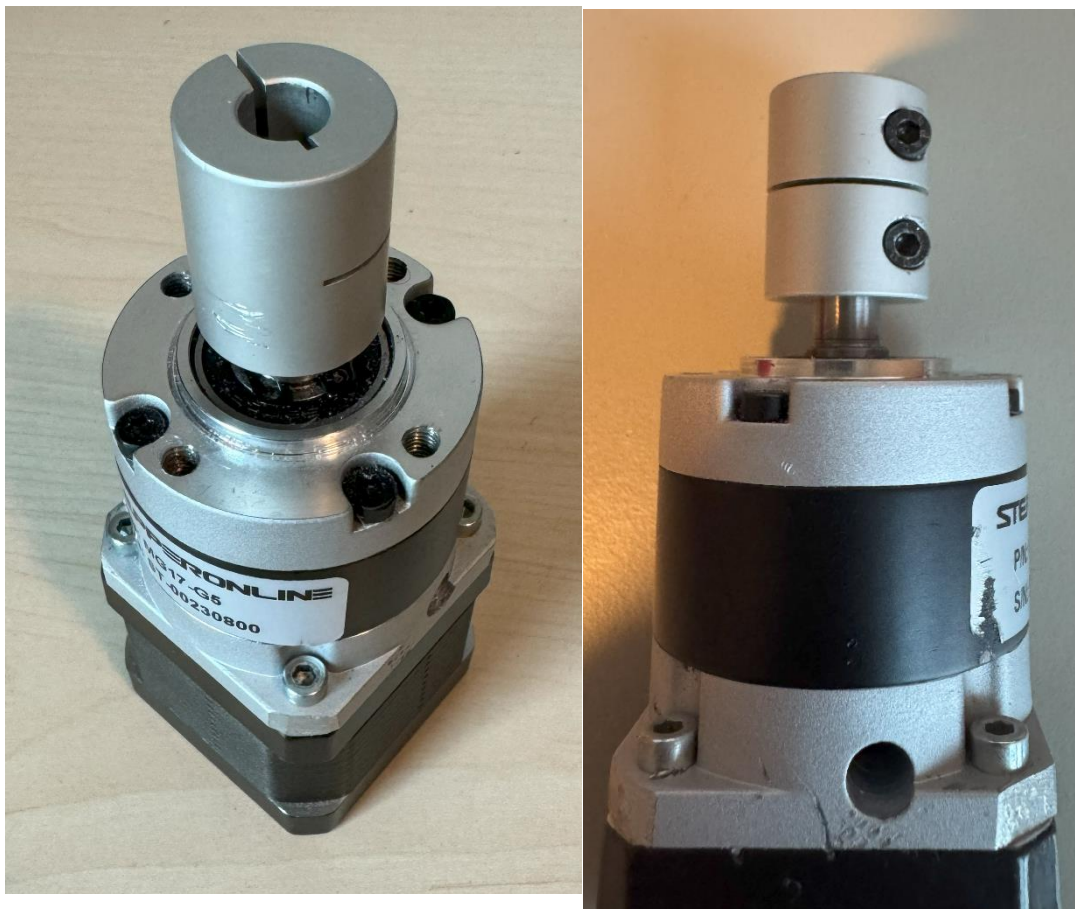

Step 11:

Items	QTY	Description
ROBOT_014	1	
DIN 912 M4 x 25	4	Hexagon socket Head Cap Screws M4x25
ISO 4032 M5	4	Hexagon regular nut M5

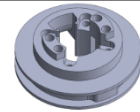

Instruction:

First, insert the M5 nuts. Then, mount the motor with the gearbox onto the 3D-printed part. Ensure that the motor's wire connection is facing upwards when positioning the 3D-printed parts as shown in the image below. Also, set the coupling in the position indicated in the image.

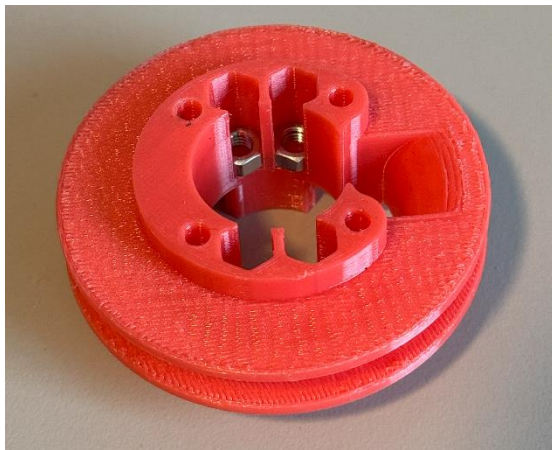

Step 12:

Items	QTY	Description
BEARING_04	2	Bearing 40x52x7 (6808)
BEARING_08	2	Axial bearing 50x70x5 (AXK5070 2AS)
DIN 912 M5 x 60	4	Hexagon socket Head Cap Screws M5x60

Instruction:

Do not yet tighten the M5 x 60 bolts yet, make sure you can still access the set screw, see picture below.

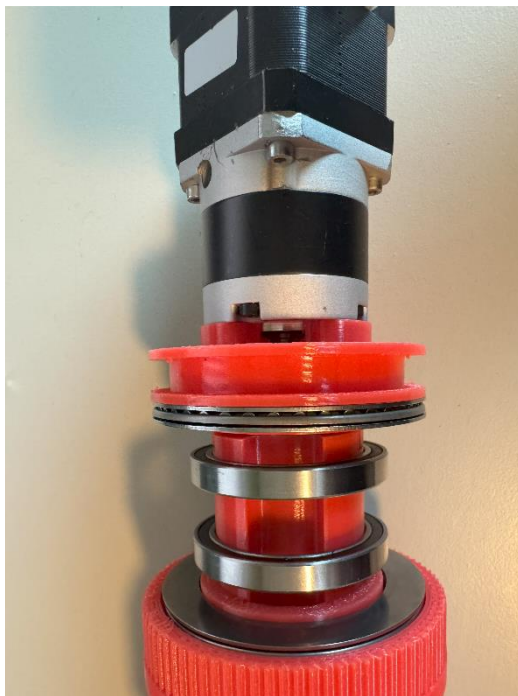

Step 13:

Items	QTY	Description
ROBOT_010	1	
ISO 4032 M5	1	Hexagon regular nut M5

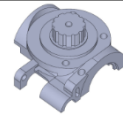

Instruction:

Insert the M5 nut, if the nut is to lose and is falling out use a bit of glue

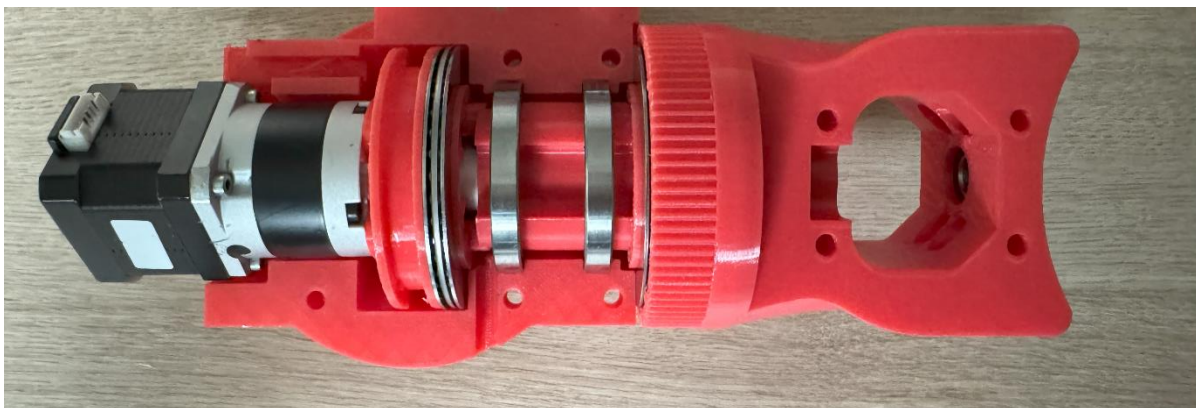
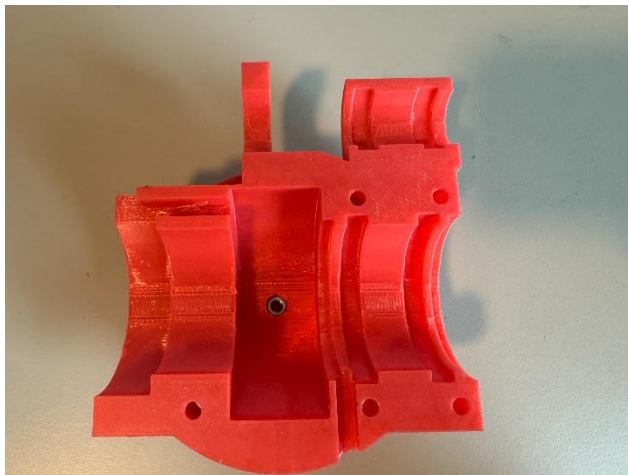

Step 14:

Items	QTY	Description
BEARING_03	2	Bearing 8x22x7 (608)
AXIS_01	1	Axis Ø8 L65
COUPLING_01	1	Coupler Ø 8 - Ø 5
PULLEY_03	1	Pulley HTD3M 16t W10 B8

Instruction:

Make sure that there is ± 1 mm of clearance between the 3d printed part and the pulley, same with the coupler

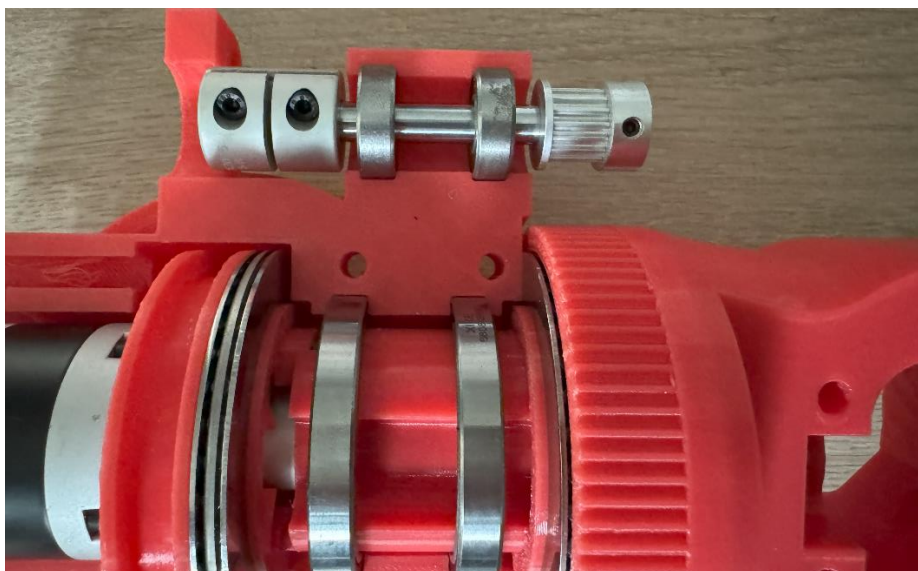
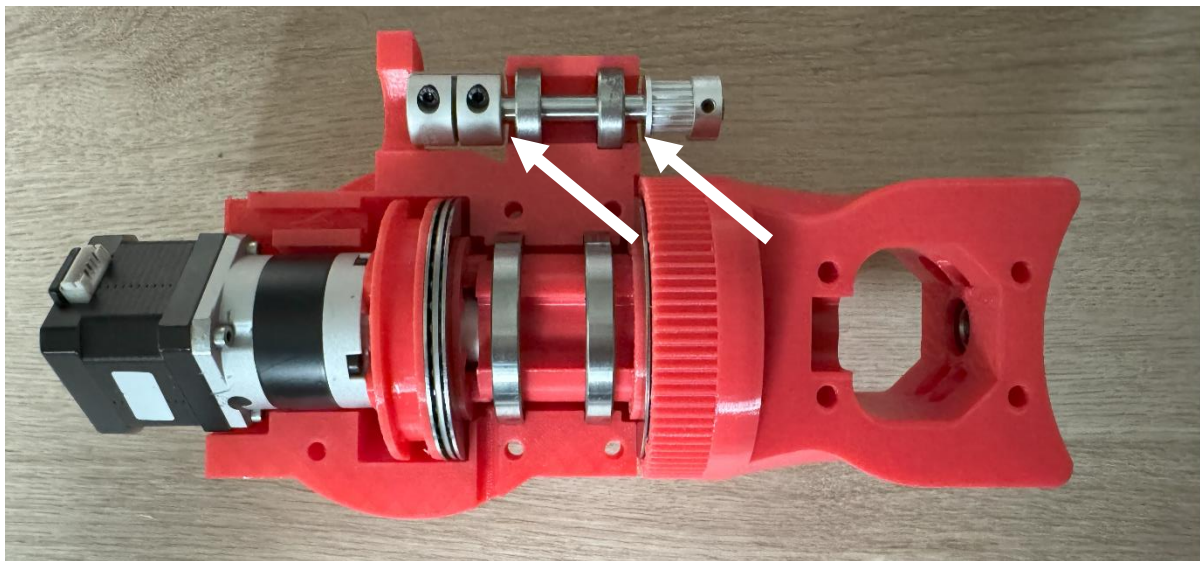

Step 15:

Items	QTY	Description
AXIS_04	1	Axis Ø8 L145
PULLEY_03	1	Pulley HTD3M 16t W10 B8
BELT_08	1	Timing belt HTD3M L420 W10

Instruction:

Note the position of the pulley, and do not tighten the pulley yet. But tighten the coupling.

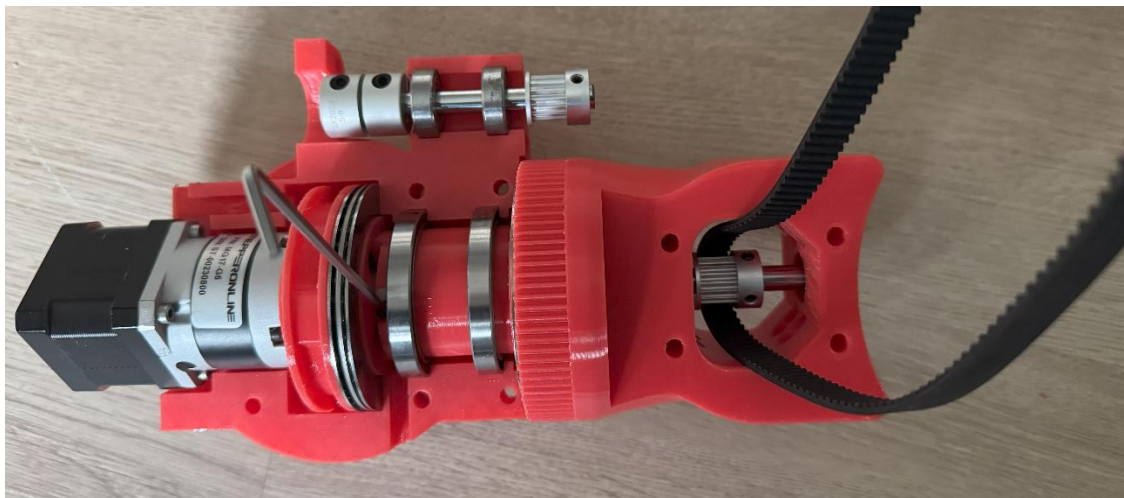

Step 16:

Items	QTY	Description
ROBOT_011	1	
DIN 912 M5 x 35	5	Hexagon socket Head Cap Screws M5x35
ISO 4032 M5	6	Hexagon regular nut M5

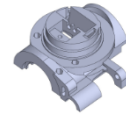

Instruction:

First insert the M5 nut on the back of the part, after that use the bolts and nuts to assembly the parts together. At last you can tighten the 4 M5 bolt of Step 12, make sure the assembly can still turn.

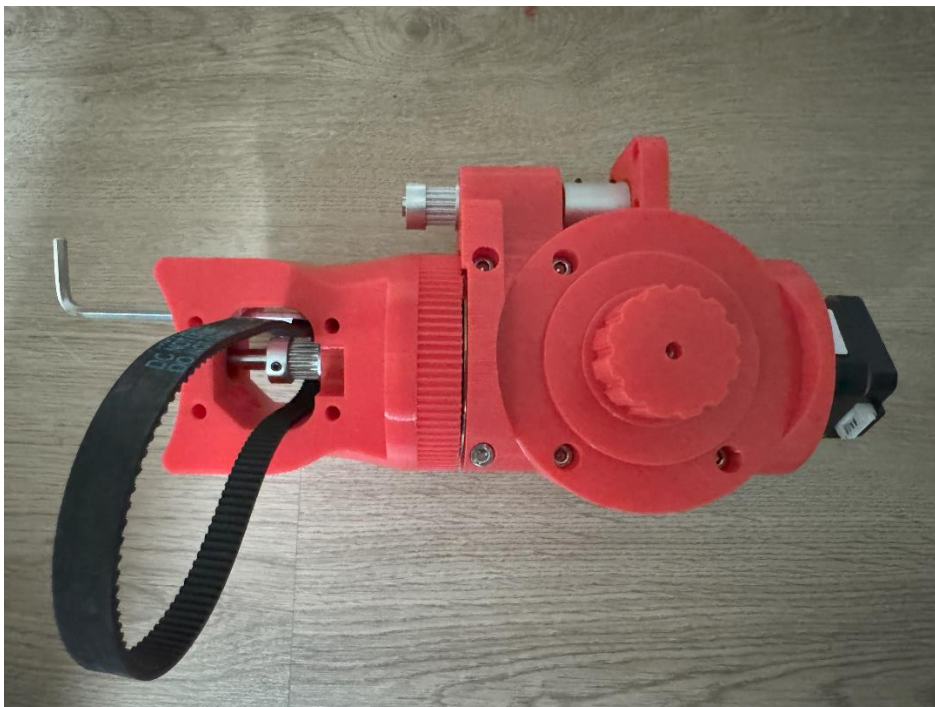
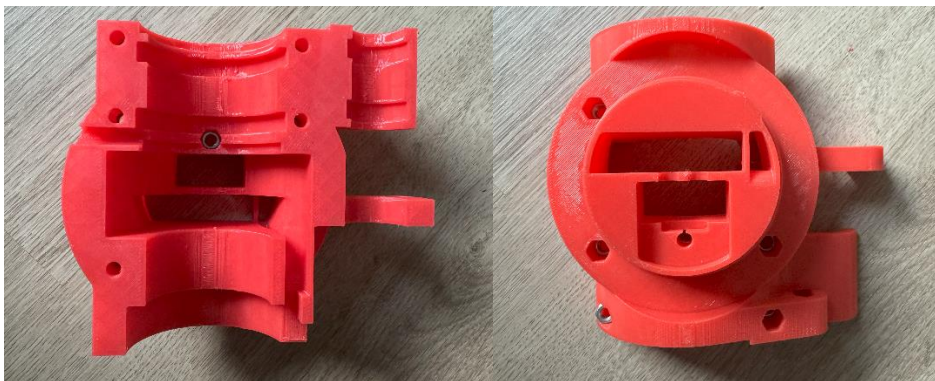

Step 17:

Items	QTY	Description
DIN 912 M3 x 10	4	Hexagon socket Head Cap Screws M3x10
DIN 125 M3	4	Washer M3
MOTOR_04	1	Stepper motor Nema 17 L48
CABLE_03	1	Nema 17 cable 50 cm

Instruction:

First connect the cable to the motor, after this move the cable through the back of the assembly, see picture. Next mount the motor using M3 x 10 bolts with the M3 washers.

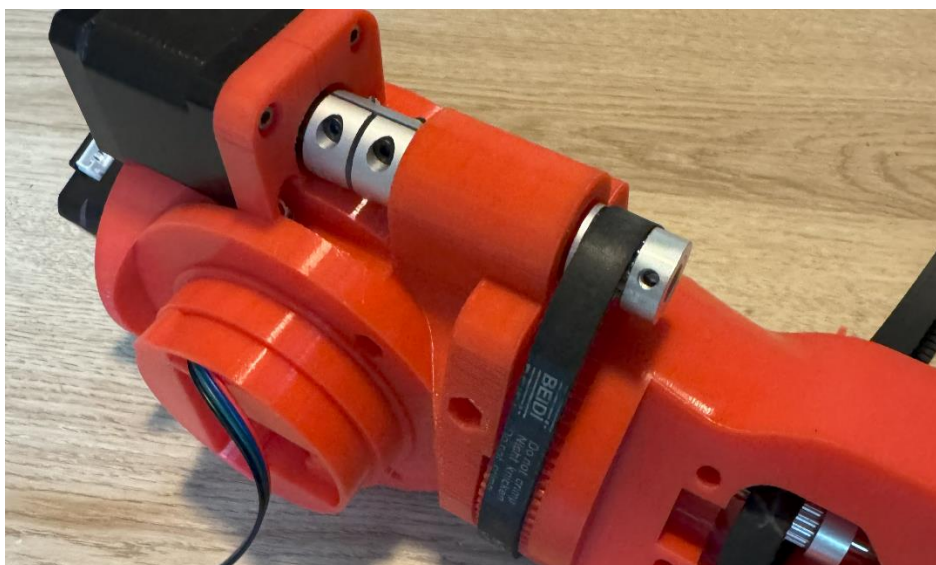
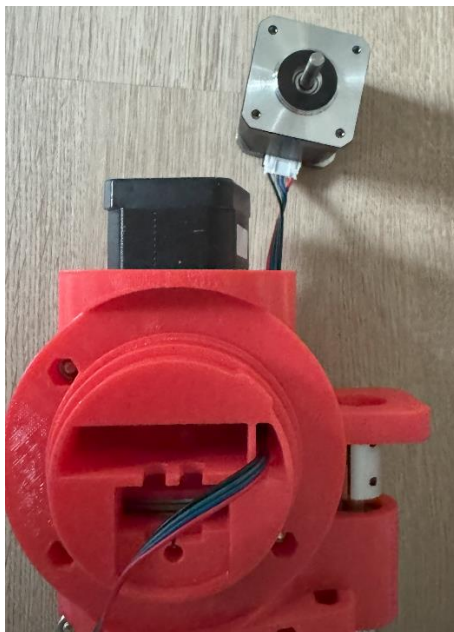

Step 18:

Items	QTY	Description
BELT_03	1	Timing belt HTD 3M 294 W10
BEARING_01	4	Bearing 5x14x5 (605)
DIN 912 M5 x 20	2	Hexagon socket Head Cap Screws M5x20
ISO 4032 M5	2	Hexagon regular nut M5
DIN 125 M5	2	Washer M5

Instruction:

First mount the belt, after that mount the bearings for tensioning the belt make sure to put a M5 washer between the bearing and the 3d printed part.



Step 19:

Items	QTY	Description
ROBOT_008	1	
BEARING_04	1	Bearing 40x52x7 (6808)
ISO 4032 M5	6	Hexagon regular nut M5
ISO 4032 M3	3	Hexagon regular nut M3



Instruction:

Insert the nuts and bearing as shown in picture below

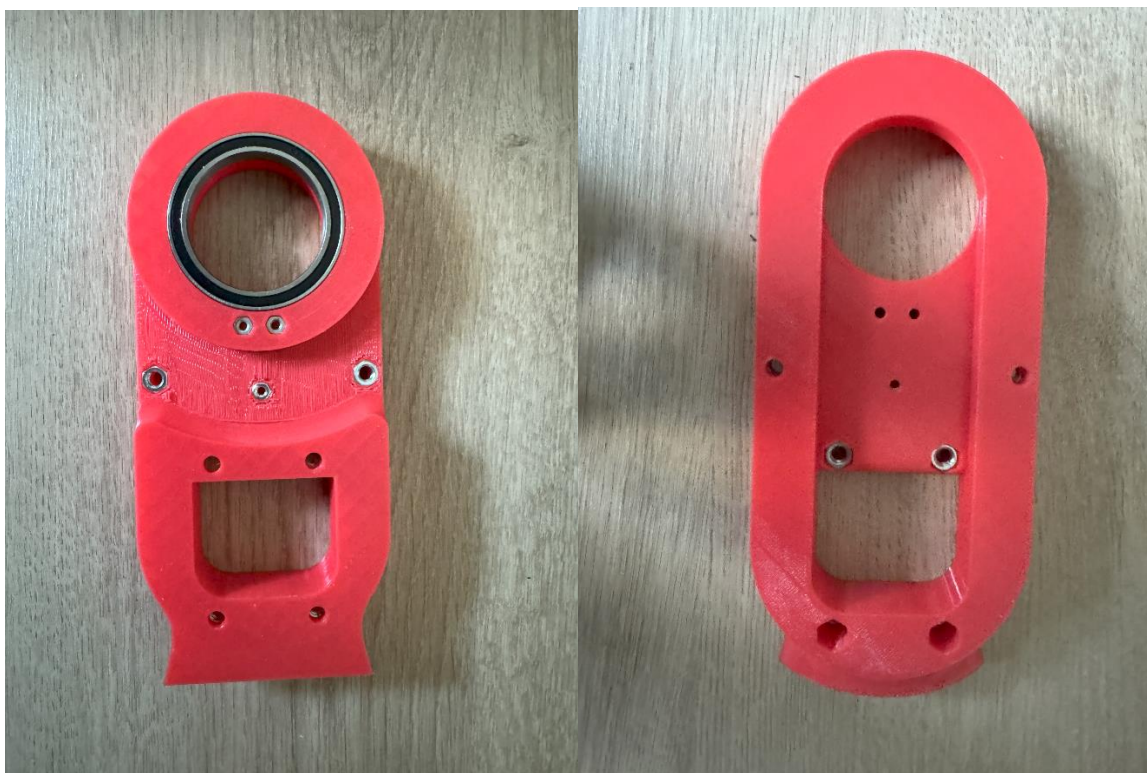

Step 20:

Items	QTY	Description
ROBOT_041	1	
LIM_SWITCH_05	1	
DIN 912 M3 x 10	1	Hexagon socket Head Cap Screws M3x10
DIN 912 M3 x 16	2	Hexagon socket Head Cap Screws M3x16



Instruction:

Mount the limit switch with the M3 x 16 bolts, after that use ROBOT_041 to hold the cables in place, use M3x10 for this. At last screw the female part of ELECTRONICS_024 to the cable of the limit switch



Step 21:

Items	QTY	Description
ROBOT_007	1	
BEARING_004	1	Bearing 40x52x7 (6808)
ISO 4032 M5	6	Hexagon regular nut M5



Instruction:

Insert the M5 nuts and bearing, see image below

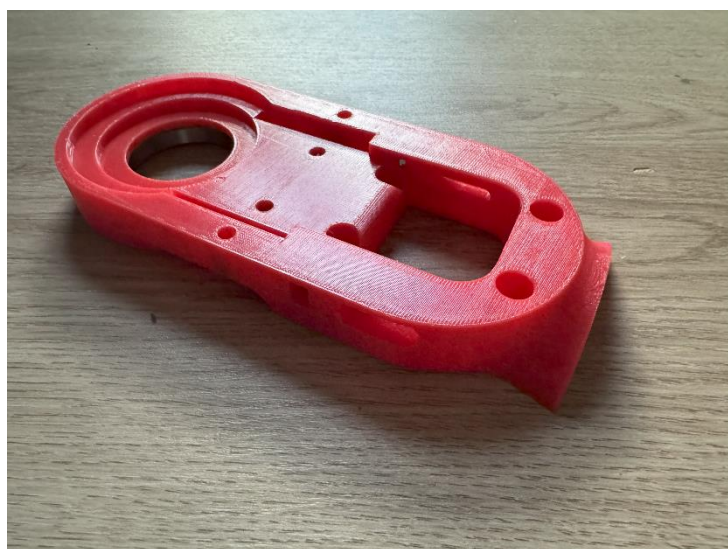

Step 22:

Items	QTY	Description
BEARING_01	8	Bearing 5x14x5 (605)
ISO 4032 M5	1	Hexagon regular nut M5
DIN 913 M5 x 35	2	Set screw M5 x 35
DIN 912 M5 x 60	1	Hexagon socket Head Cap Screws M5x60

Instruction:



Step 23:

Items	QTY	Description
DIN 912 M5 x 60	4	Hexagon socket Head Cap Screws M5x60

Instruction:

Use the M5 x 60 bolts to mount the assemblies from the previous steps together

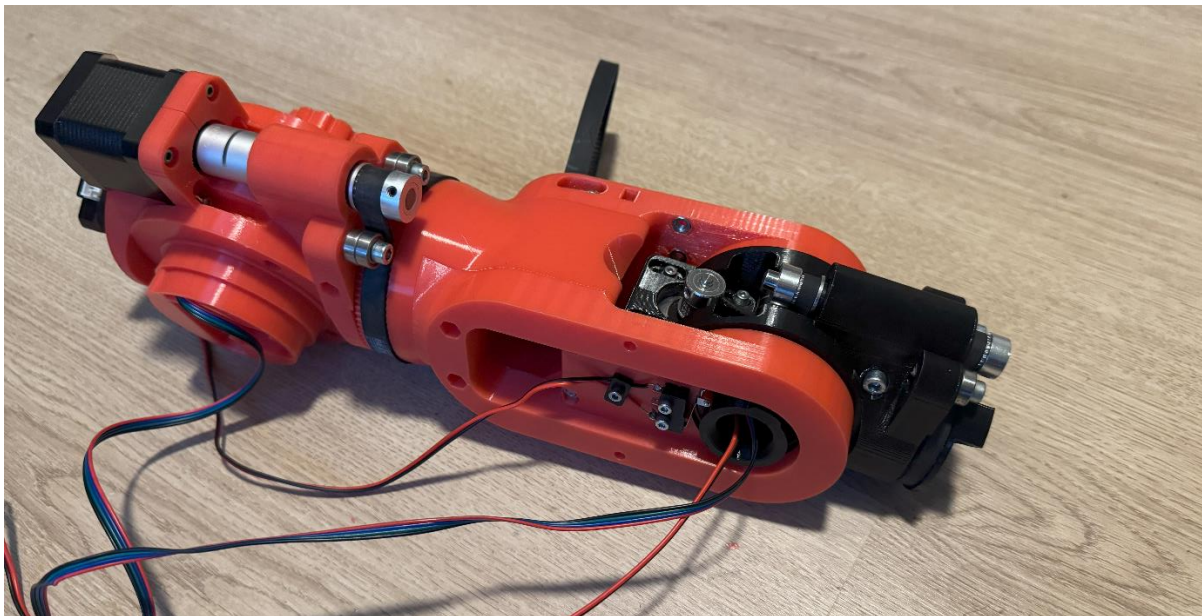
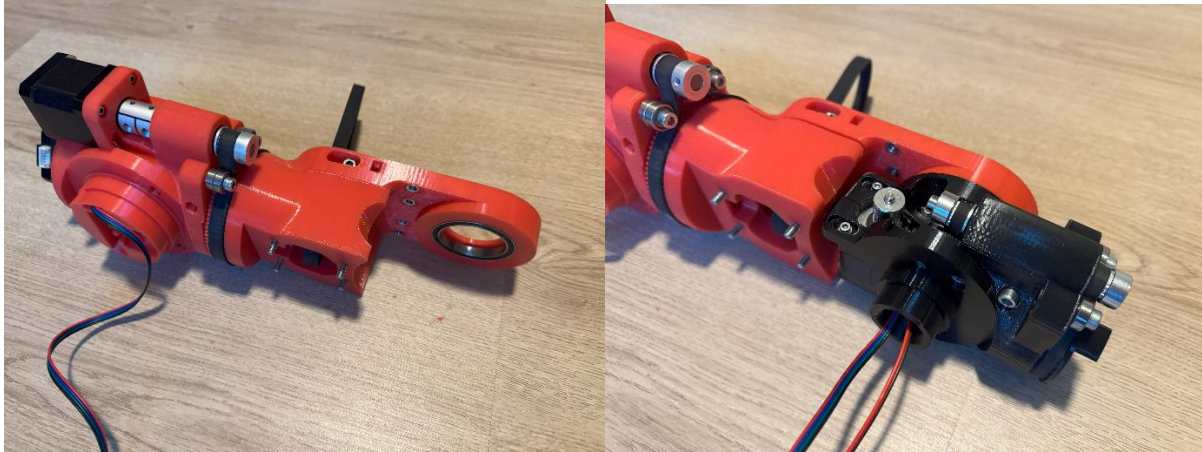

Step 24:

Items	QTY	Description
ROBOT_035	1	
BEARING_09	1	Axial bearing Ø52x35x4 (AXK3552 2AS)
DIN 912 M5 x 35	1	Hexagon socket Head Cap Screws M5x35
DIN 125 M5	1	Washer M5

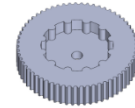

Instruction:

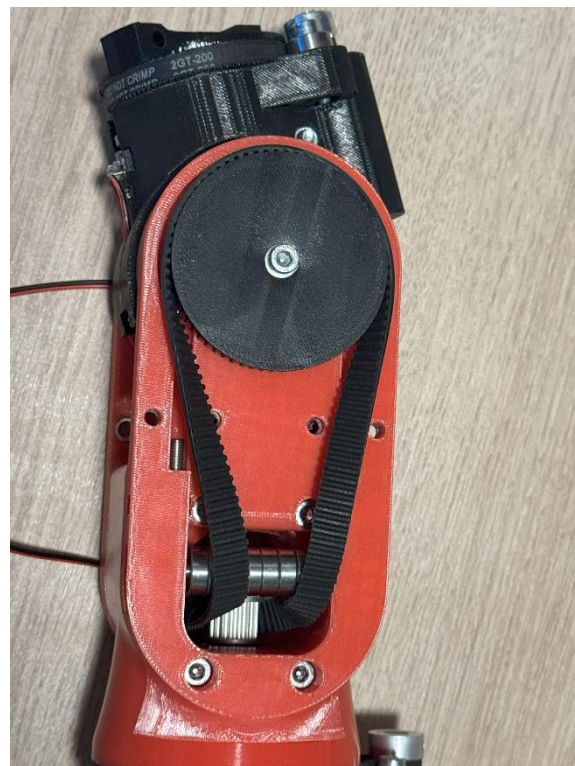

Step 25:

Items	QTY	Description
BEARING_01	4	Bearing 5x14x5 (605)
DIN 912 M5 x 20	2	Hexagon socket Head Cap Screws M5x20
DIN 125 M5	2	Washer M5

Instruction:



Step 26:

Items	QTY	Description
ROBOT_012	1	
DIN 912 M5 x 20	2	Hexagon socket Head Cap Screws M5x20



Instruction:



Step 27:

Items	QTY	Description
CABLE_02	1	3P Dupont cable male 100cm

Instruction:

Move the cable through the assembly, if you are also using the IO box you have to put another 2-wire cable and an air-tube, cut a 350 mm part of the 3P dupont cable and also route through the assembly like the other cables.

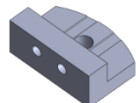

Step 28:

Items	QTY	Description
ROBOT_015	1	
LIM_SWITCH_04	1	
ISO 4032 M3	2	Hexagon regular nut M3
DIN 912 M3 x 16	2	Hexagon socket Head Cap Screws M3x16
DIN 912 M5 x 20	1	Hexagon socket Head Cap Screws M5x20

Instruction:

Make sure you mount the limit switch in the same orientation

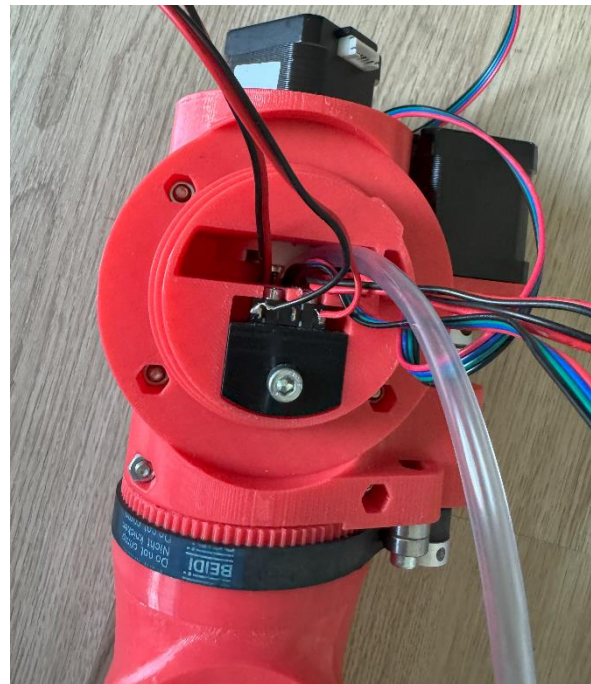

Step 29:

Items	QTY	Description
CABLE_03	1	Nema 17 cable 50 cm

Instruction:

Connect the cable to the Nema 17 motor and route the cable through the 3D printed part as shown in the image below.

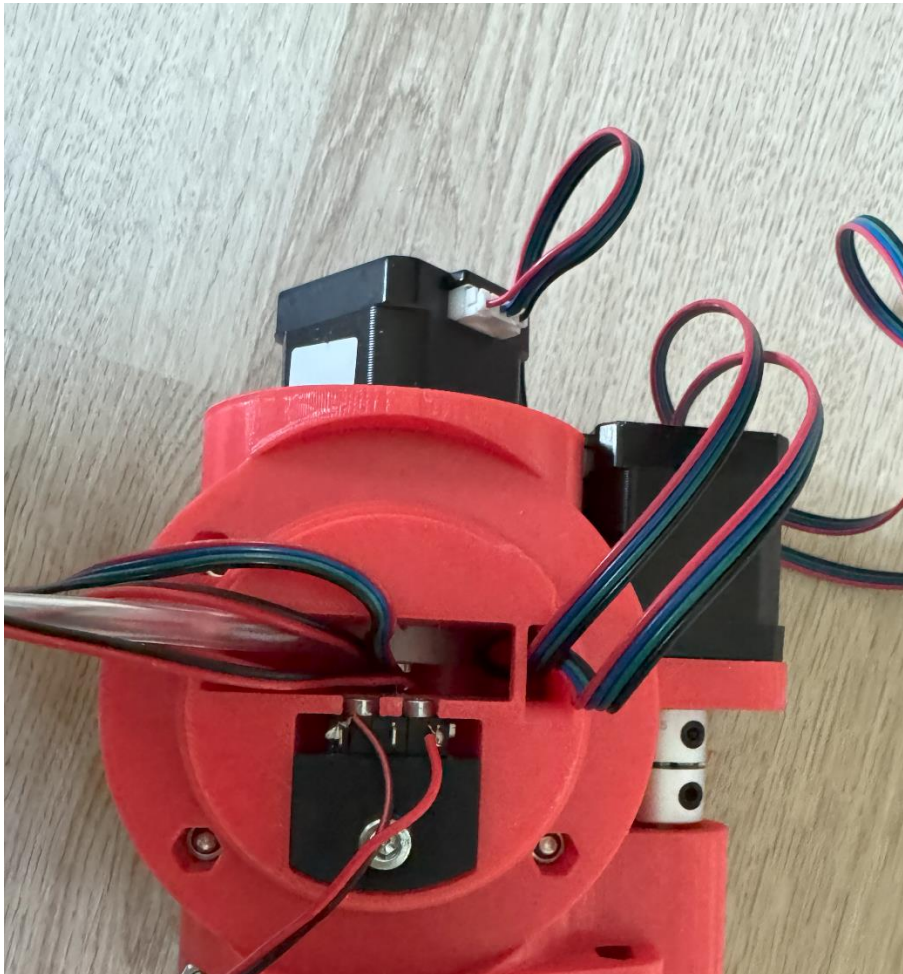

Step 30:

Items	QTY	Description
ROBOT_013	1	
ELECTRONICS_007	1	USB connector 2 pin
ELECTRONICS_005	1	5,5 x 2,1 mm jack
ELECTRONICS_022	1	15EDGRK 3.81 03P Male and female screw
ELECTRONICS_024	1	15EDGRK 3.81 02P Male and female screw
CABLE_02	1	3P Dupont cable male 100cm
CABLE_01	0.05 m	Cable 2 wire, 22 AWG/ 0.34 mm ²



Instruction:

Solder CABLE_01 to the 5,5 mm jack, short pin is + long pin is -. *
 Connect the 02P connector male to the cable of the 5,5 m jack. *

Next shorten the wire of the USB connector, to ± 5 0mm. If the connector has 4 wires remove the wire except the red and black wire.

Shorten the 3P dupont cable to around ± 50 mm, male side.

Mount the USB connector and 5,5 mm jack to the 3d printed part

Connect the 03P connector male to USB connector and the 3P dupont cable.

The picture is showing the female side of the 3P dupont cable but it should be the male side!

*only if you are using the IO box

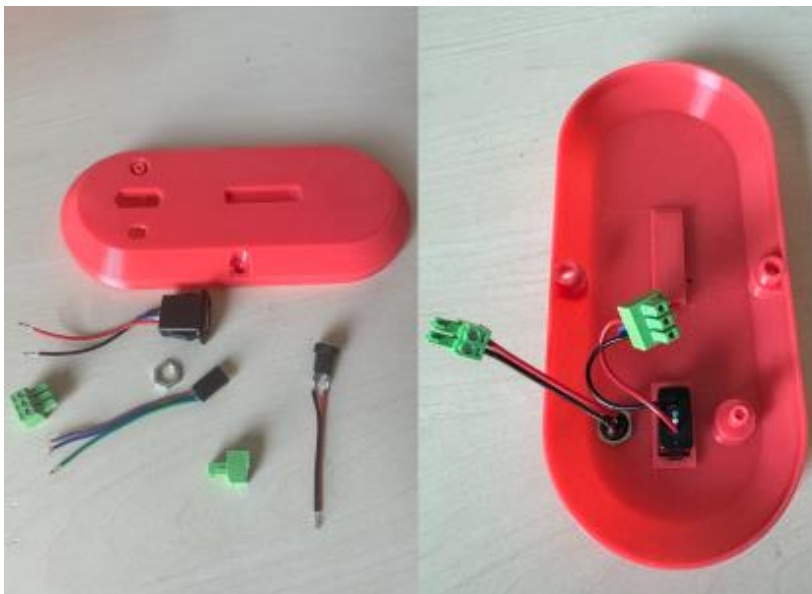

Step 31:

Items	QTY	Description
DIN 912 M5 x 20	2	Hexagon socket Head Cap Screws M5x20
ELECTRONICS_022	1	15EDGRK 3.81 03P Male and female screw

Instruction:

If you are using the IO box also use the ELECTRONICS_024

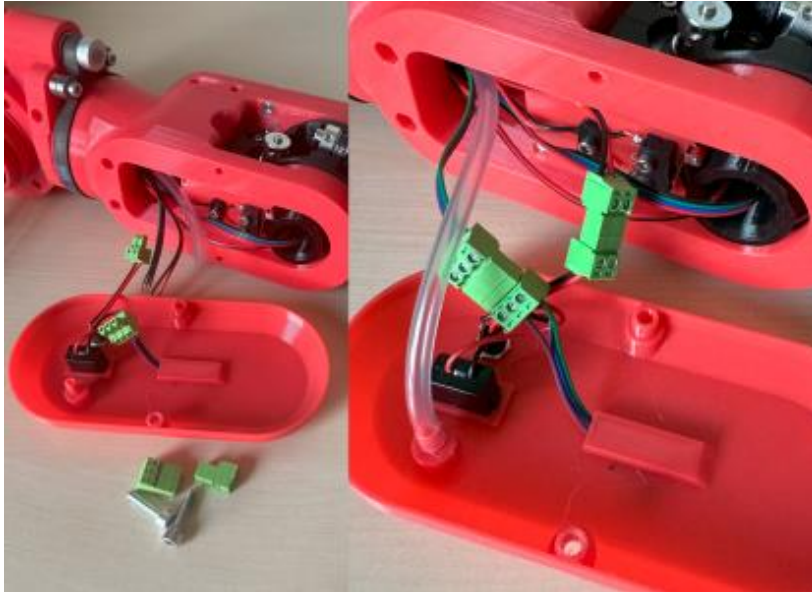

Step 32:

Items	QTY	Description
ROBOT_025	1	
BEARING_04	1	Bearing 40x52x7 (6808)
BEARING_06	1	Bearing 80x100x10 (6816)
ISO 4032 M5	2	Hexagon regular nut M5

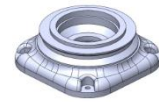

Instruction:

Press the 2 bearings in place and insert the 2 nuts

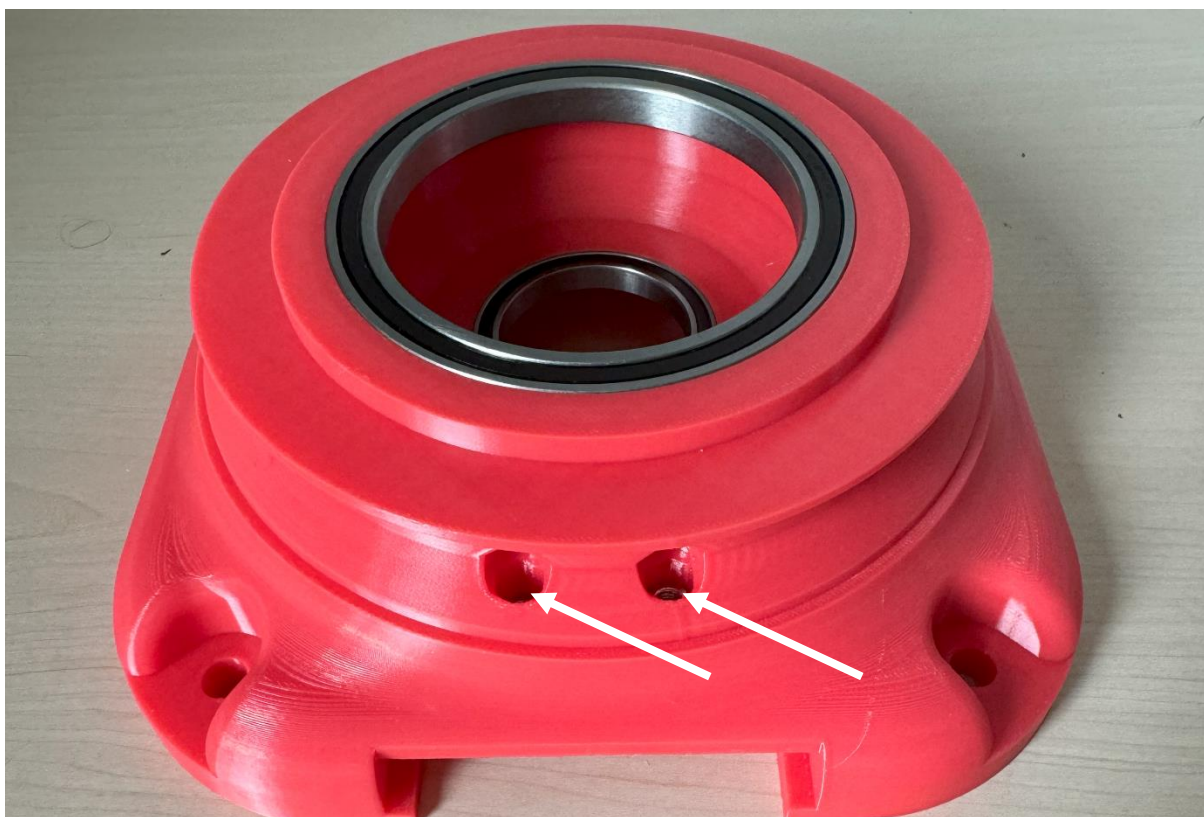

Step 33:

Items	QTY	Description
ROBOT_023	1	
ISO 4032 M5	4	Hexagon regular nut M5
ISO 4032 M8	4	Hexagon regular nut M8

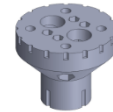

Instruction:

Insert the nuts. Next insert this assembly in the assembly of the previous step



Step 34:

Items	QTY	Description
ROBOT_026	1	
ROBOT_046	1	
BEARING_08	1	Axial bearing 50x70x5 (AXK5070 2AS)
DIN 912 M5 x 60	4	Hexagon socket Head Cap Screws M5x60

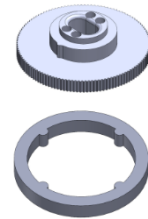

Instruction:

Tighten the bolts completely

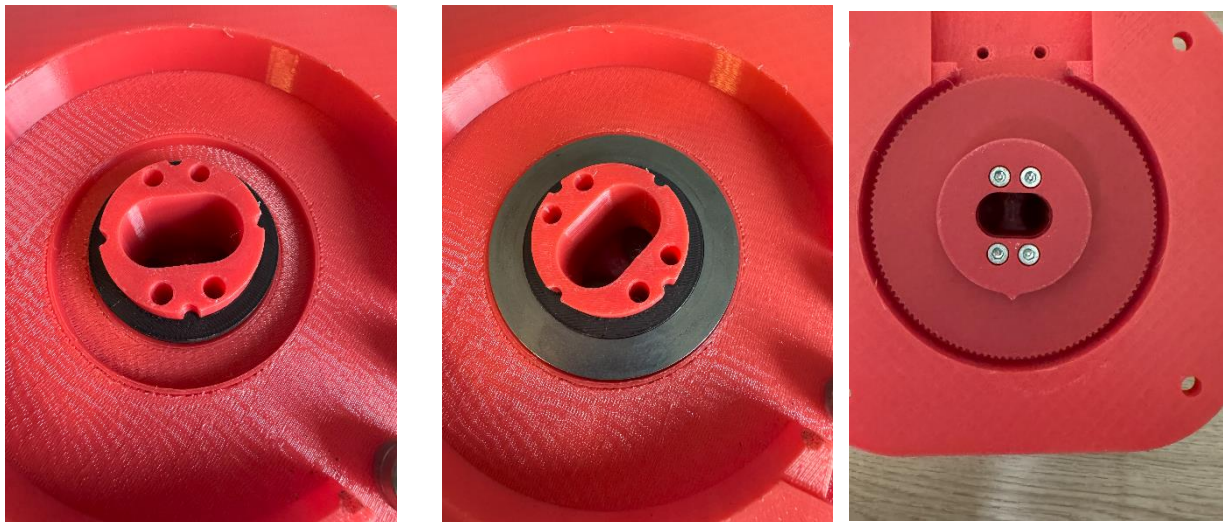

Step 35:

Items	QTY	Description
ROBOT_022	1	
ISO 4032 M5	3	Hexagon regular nut M5
ISO 4032 M8	4	Hexagon regular nut M8

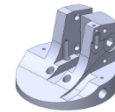

Instruction:

Insert the nuts as shown on the picture below

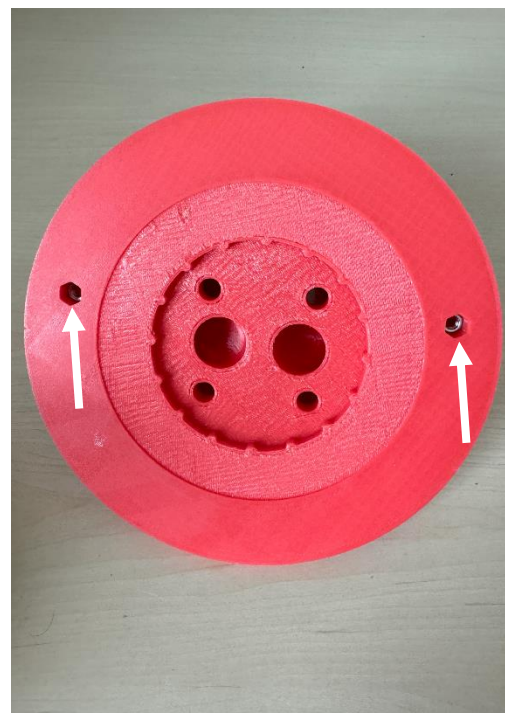
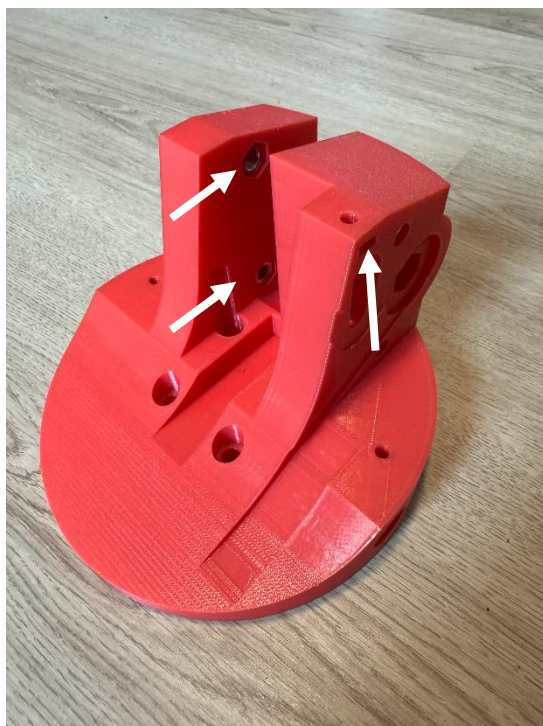

Step 36:

Items	QTY	Description
ROBOT_024	1	
BEARING_10	1	Axial bearing 120x155x6 (AXK120155 2AS)
DIN 912 M8 x 45	4	Hexagon socket Head Cap Screws M8x45



Instruction:

During the assembly make sure that the nod on the pulley is facing the right directions, see pictures below. Secondly after tightening the M8 bolts make sure the assembly can still spin properly.



Step 37:

Items	QTY	Description
ROBOT_017	1	
MOTOR_02	1	Stepper motor Nema 23 L76
PULLEY_07	1	Pulley HTD3M 12T W10 B6.35
DIN 912 M5 x 60	4	Hexagon socket Head Cap Screws M5x60
ISO 4032 M5	6	Hexagon regular nut M5

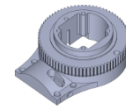

Instruction:

First put pulley on the motor shaft as shown in the picture below, make sure that the pulley does not touch the motor, keep a clearance of max 1 mm. when mounting the motor to the 3d printed part make sure the wires of the motor are on the top side, see picture. At last insert the two M5 bolts.



Step 38:

Items	QTY	Description
ROBOT_016	1	
MOTOR_02	1	Stepper motor Nema 23 L76
PULLEY_07	1	Pulley HTD3M 12T W10 B6.35
DIN 912 M5 x 60	4	Hexagon socket Head Cap Screws M5x60
ISO 4032 M5	9	Hexagon regular nut M5

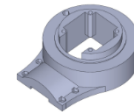

Instruction:

First put pulley on the motor shaft as shown in the picture below, make sure that the pulley does not touch the motor, keep a clearance of max 1 mm. when mounting the motor to the 3d printed part make sure the wires of the motor are on the top side, see picture. At last insert the two M5 bolts.



Step 39:

Items	QTY	Description
ROBOT_031	1	
BEARING_06	1	Bearing 80x100x10 (6816)
BEARING_02	1	Bearing 10x30x9 (6200)
ISO 4032 M5	7	Hexagon regular nut M5
ISO 4032 M3	1	Hexagon regular nut M3



Instruction:

First insert the M5 nuts and the M3 nut after that press the bearings in the right place see pictures below.



Step 40:

Items	QTY	Description
ROBOT_028	1	
BEARING_06	1	Bearing 80x100x10 (6816)
BEARING_02	1	Bearing 10x30x9 (6200)
ISO 4032 M5	4	Hexagon regular nut M5



Instruction:

Insert the bearings and the nuts

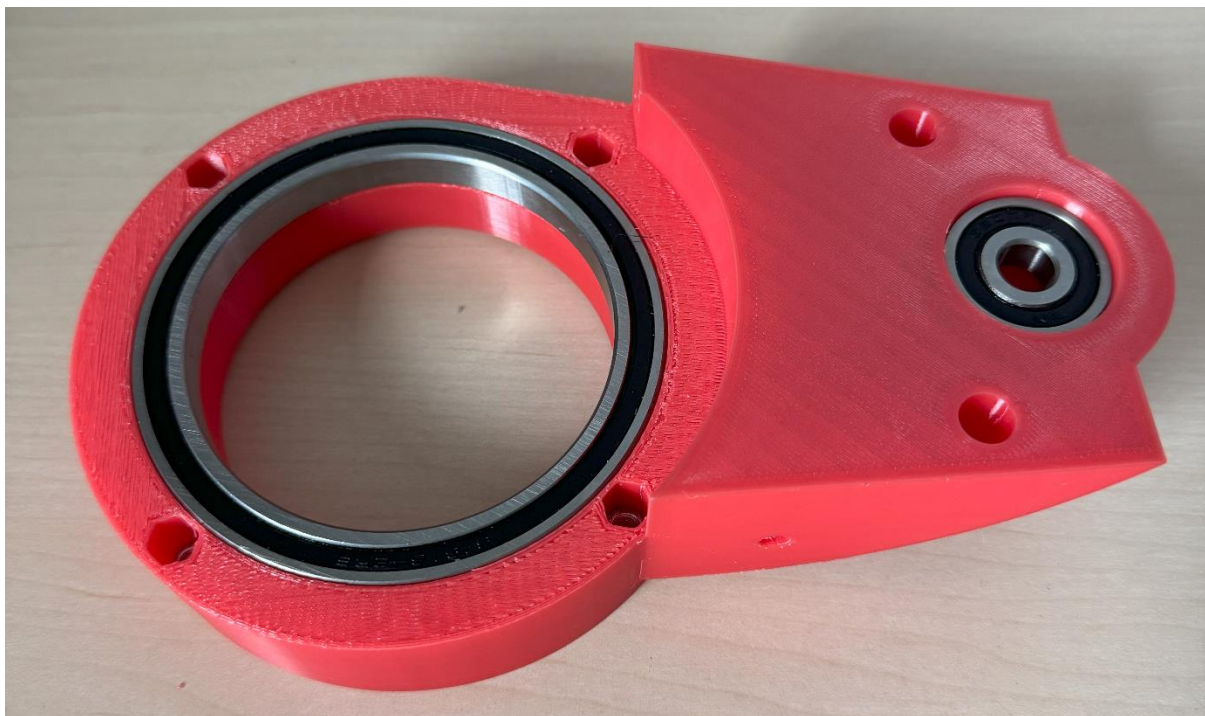

Step 41:

Items	QTY	Description
ROBOT_037	1	
ROBOT_038	1	
ROBOT_039	1	
PULLEY_04	1	Pulley HTD3M 90t W10 B10
PULLEY_06	1	Pulley HTD5M 15T W15 B10
BELT_05	1	Timing belt HTD3M L393 W10
AXIS_03	1	Axis Ø10 L135

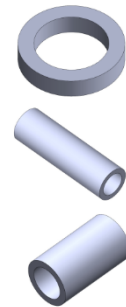

Instruction:

Mount the components as shown in the picture below, make sure to tighten the pulleys really fast.

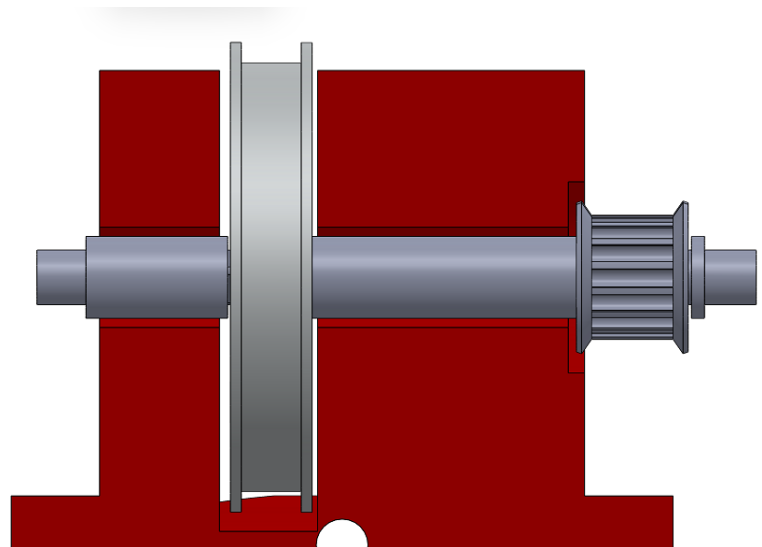

Step 42:

Items	QTY	Description
DIN 912 M8 x 45	2	Hexagon socket Head Cap Screws M8x45
DIN 912 M5 x 60	1	Hexagon socket Head Cap Screws M5x60

Instruction:



Step 43:

Items	QTY	Description
-------	-----	-------------

Instruction:



Step 44:

Items	QTY	Description
ROBOT_044	1	
BEARING_03	2	Bearing 8x22x7 (608)
ISO 4032 M5	1	Hexagon regular nut M5
AXIS_06	1	Axis Ø8 L40

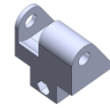

Instruction:



Step 45:

Items	QTY	Description
DIN 912 M5 x 60	1	Hexagon socket Head Cap Screws M5x60

Instruction:

Don't bring the belt at tension yet

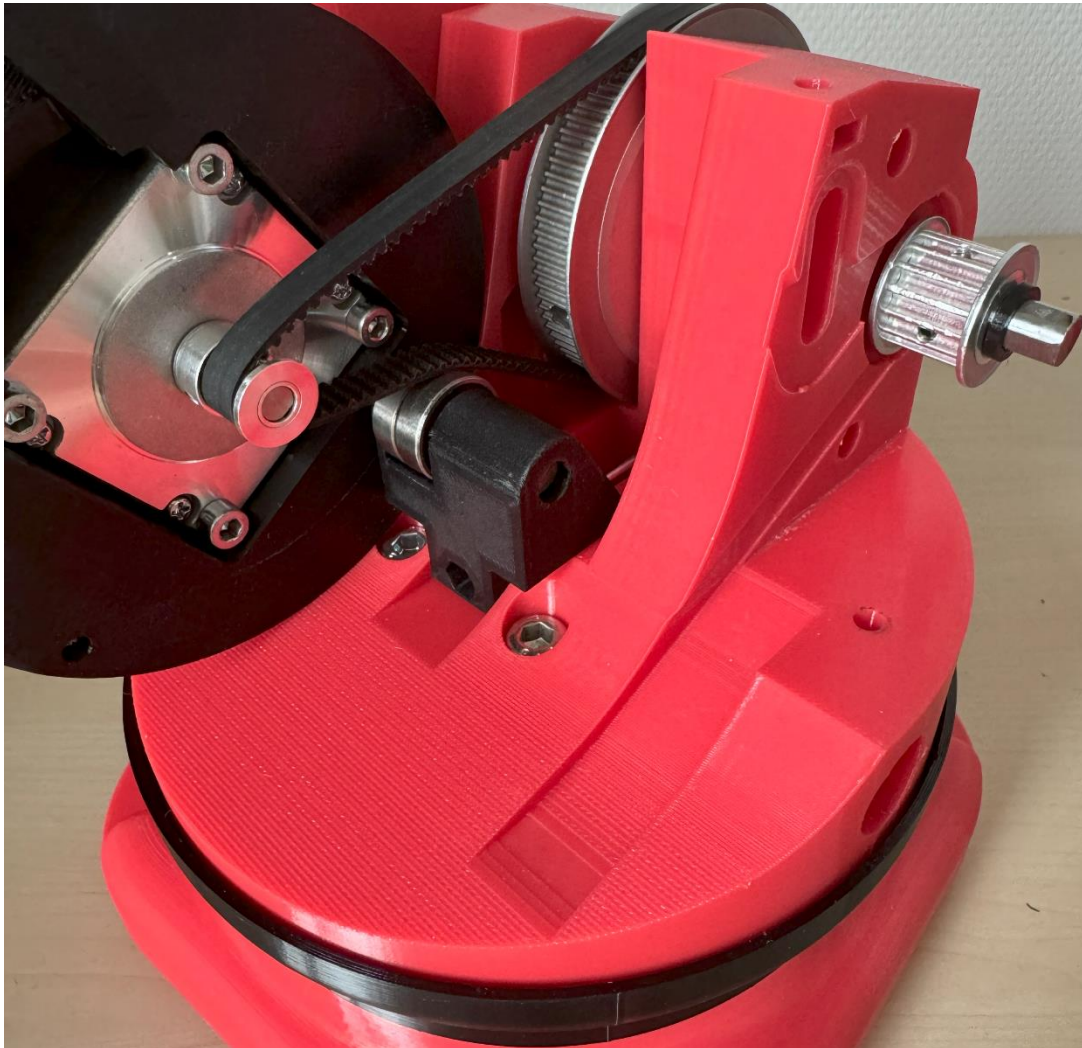

Step 46:

Items	QTY	Description
BELT_06	1	Timing belt HTD5M L500 W15
BEARING_03	2	Bearing 8x22x7 (608)
DIN 912 M8 x 45	1	Hexagon socket Head Cap Screws M8x45
DIN 125 M8	2	Washer M8

Instruction:

Make sure there is also a washer between the bearing and the 3d printed part

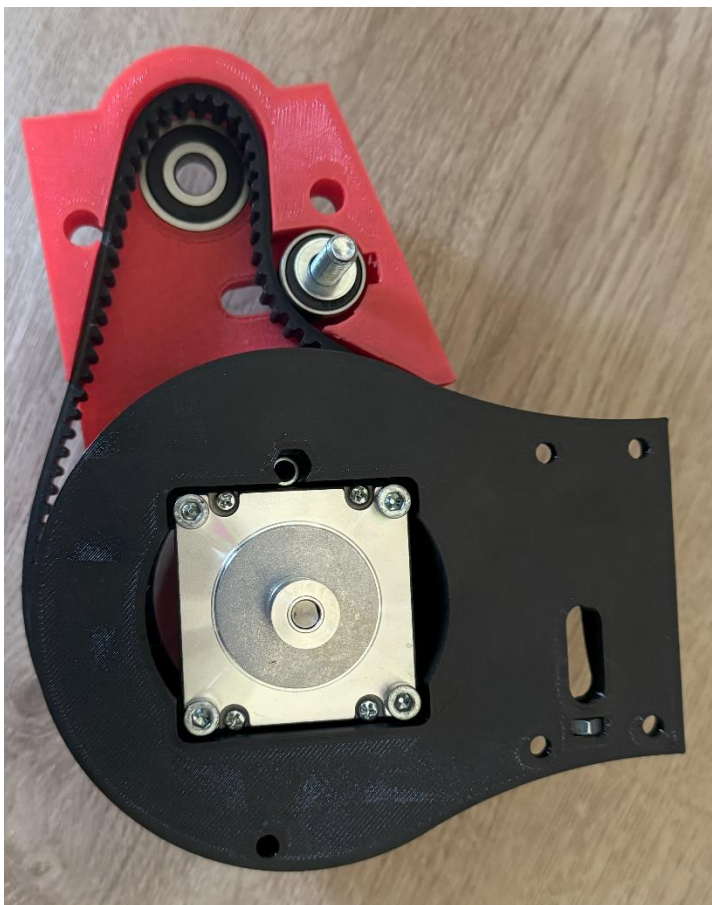

Step 47:

Items	QTY	Description
DIN 912 M8 x 45	2	Hexagon socket Head Cap Screws M8x45
DIN 912 M5 x 60	1	Hexagon socket Head Cap Screws M5x60
ISO 4032 M8	1	Hexagon regular nut M8

Instruction:

Don't tighten the bolt M8x45 used for the bearings yet.

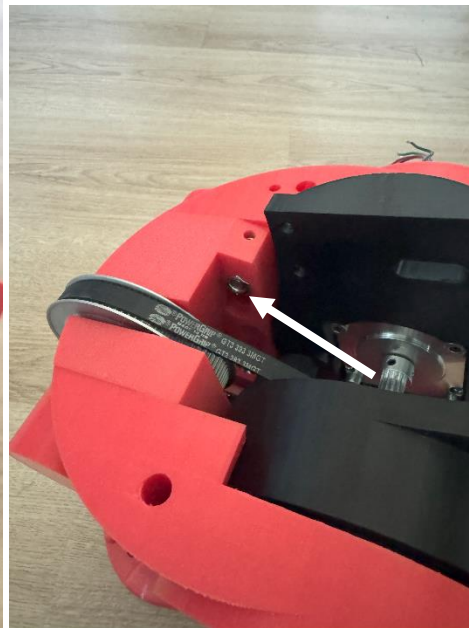

Step 48:

Items	QTY	Description
DIN 913 M5 x 35	2	Set screw M5 x 35

Instruction:

Use the set screws to tension the belt, but don't bring to much tension on the belt yet



Step 49:

Items	QTY	Description
ROBOT_018	1	
ISO 4032 M5	1	Hexagon regular nut M5
BEARING_02	1	Bearing 10x30x9 (6200)

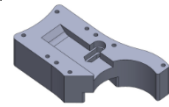

Instruction:

Insert the nut and bearing as shown in the picture below



Step 50:

Items	QTY	Description
ROBOT_036	1	
BELT_07	1	Timing belt HTD3M L345 W10
PULLEY_05	1	Pulley HTD3M 60t W10 B10
AXIS_05	1	Axis Ø10 L70



Instruction:



Step 51:

Items	QTY	Description
BEARING_03	2	Bearing 8x22x7 (608)
DIN 912 M8 x 45	1	Hexagon socket Head Cap Screws M8x45
DIN 125 M8	2	Washer M8

Instruction:

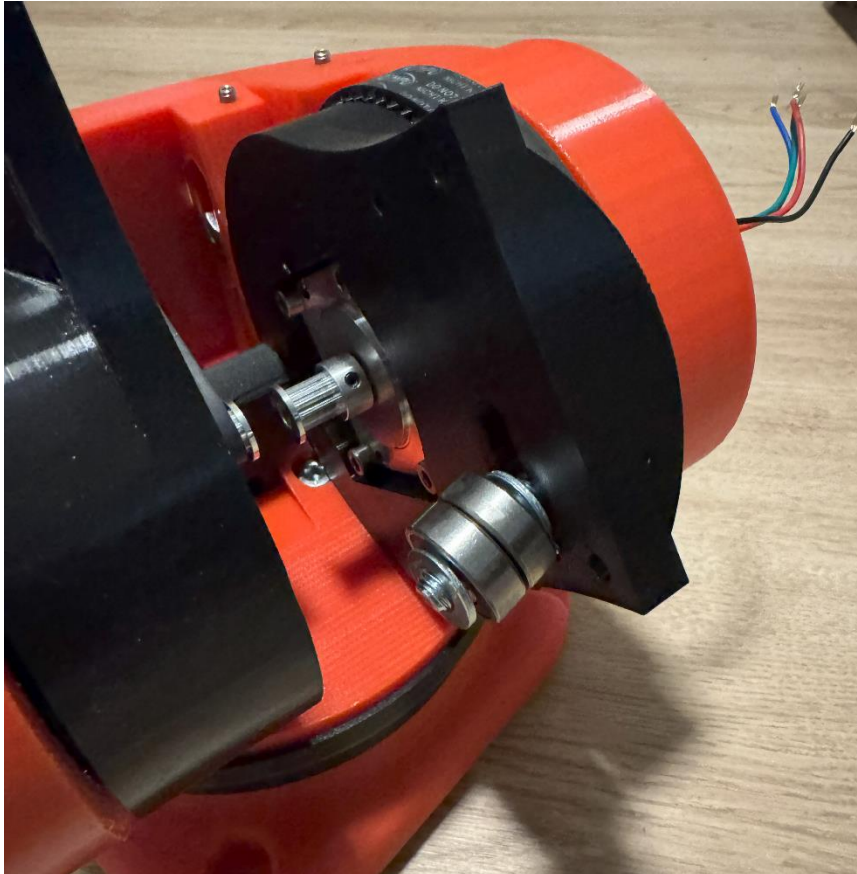

Step 52:

Items	QTY	Description
ISO 4032 M8	1	Hexagon regular nut M8

Instruction:

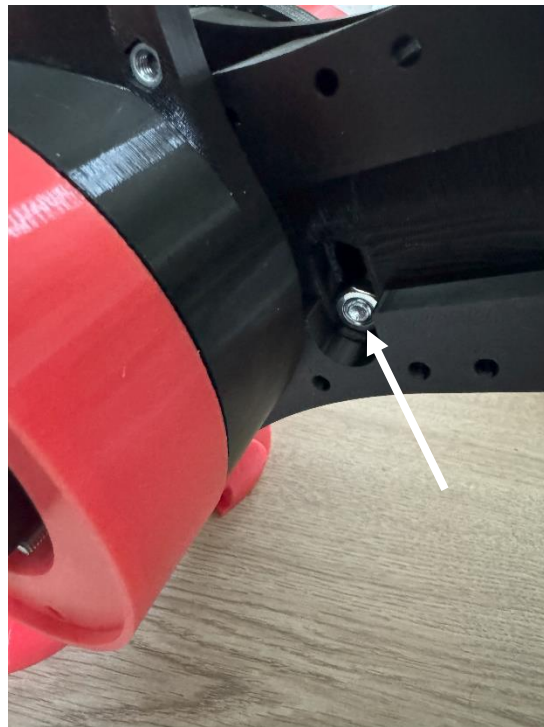
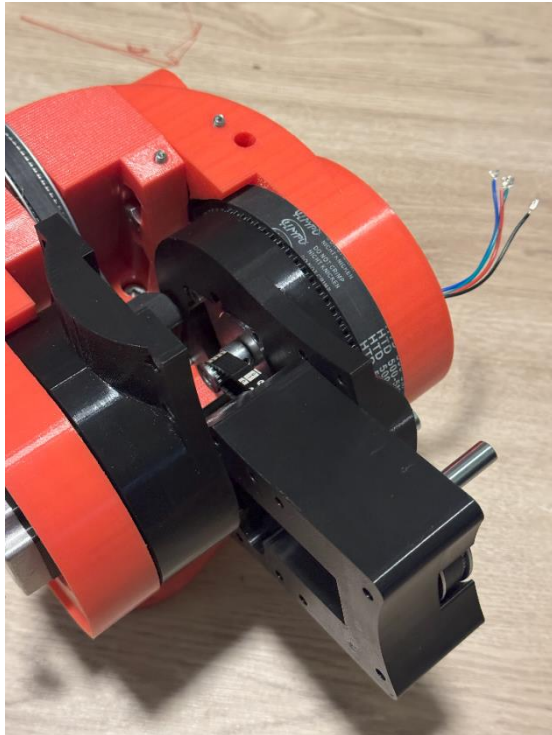

Step 53:

Items	QTY	Description
ROBOT_036	1	
DIN 912 M5 x 60	5	Hexagon socket Head Cap Screws M5x60



Instruction:

Use the M5x60 bolt to fasten the parts



Step 54:

Items	QTY	Description
ROBOT_020	1	
BEARING_04	1	Bearing 40x52x7 (6808)
BEARING_02	1	Bearing 10x30x9 (6200)
ISO 4032 M5	3	Hexagon regular nut M5
DIN 912 M5 x 20	1	Hexagon socket Head Cap Screws M5x20



Instruction:

First, insert the M5 Nuts and the bearings in the right place. After that screw the M5 bolt in place



Step 55:

Items	QTY	Description
BEARING_03	3	Bearing 8x22x7 (608)
DIN 912 M8 x 45	1	Hexagon socket Head Cap Screws M8x45
DIN 125 M8	1	Washer M8
ISO 4032 M8	1	Hexagon regular nut M8

Instruction:

Install the assembly from the steps before



Step 56:

Items	QTY	Description
DIN 912 M5 x 60	4	Hexagon socket Head Cap Screws M5x60

Instruction:

Install the assembly from step 52



Step 57:

Items	QTY	Description
-------	-----	-------------

Instruction:

Install the assembly of joint 4, 5, 6

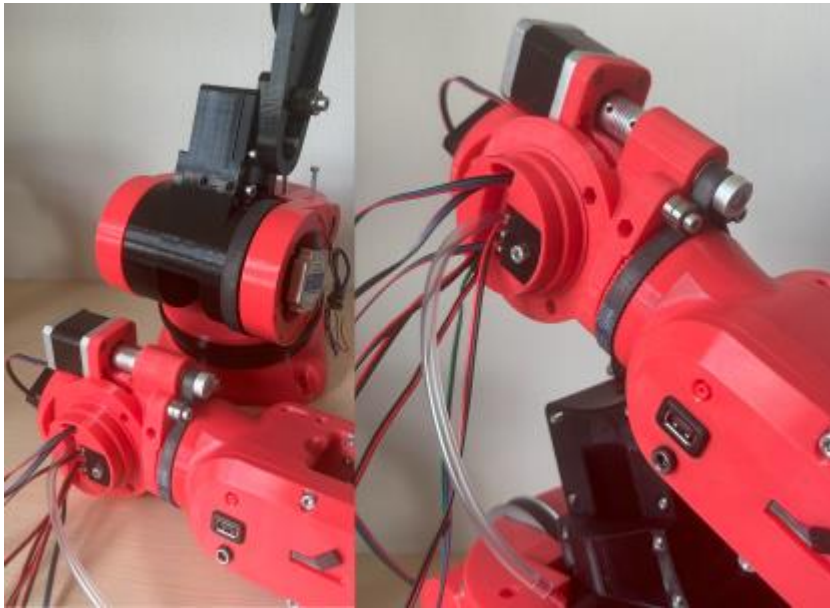

Step 58:

Items	QTY	Description
ROBOT_019	1	
BEARING_05	1	Bearing 70x90x10 (6814)
ISO 4032 M5	6	Hexagon regular nut M5
ISO 4032 M3	3	Hexagon regular nut M3

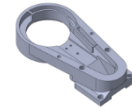

Instruction:

Insert the nuts and bearings



Step 59:

Items	QTY	Description
ROBOT_041	1	
SWITCH_3	1	
DIN 912 M3 x 10	1	Hexagon socket Head Cap Screws M3x10
DIN 912 M3 x 16	2	Hexagon socket Head Cap Screws M3x16
ELECTRONICS_024	1	15EDGRK 3.81 02P Male and female screw



Instruction:

Mount the limit switch with the M3 x 16 bolts, after that use ROBOT_041 to hold the cables in place, use M3x10 for this. At last screw the female part of ELECTRONICS_024 to the cable of the limit switch



Step 60:

Items	QTY	Description
-------	-----	-------------

Instruction:

Mount the assembly from step 56 to robot by tightening the M5 x 60 bolts

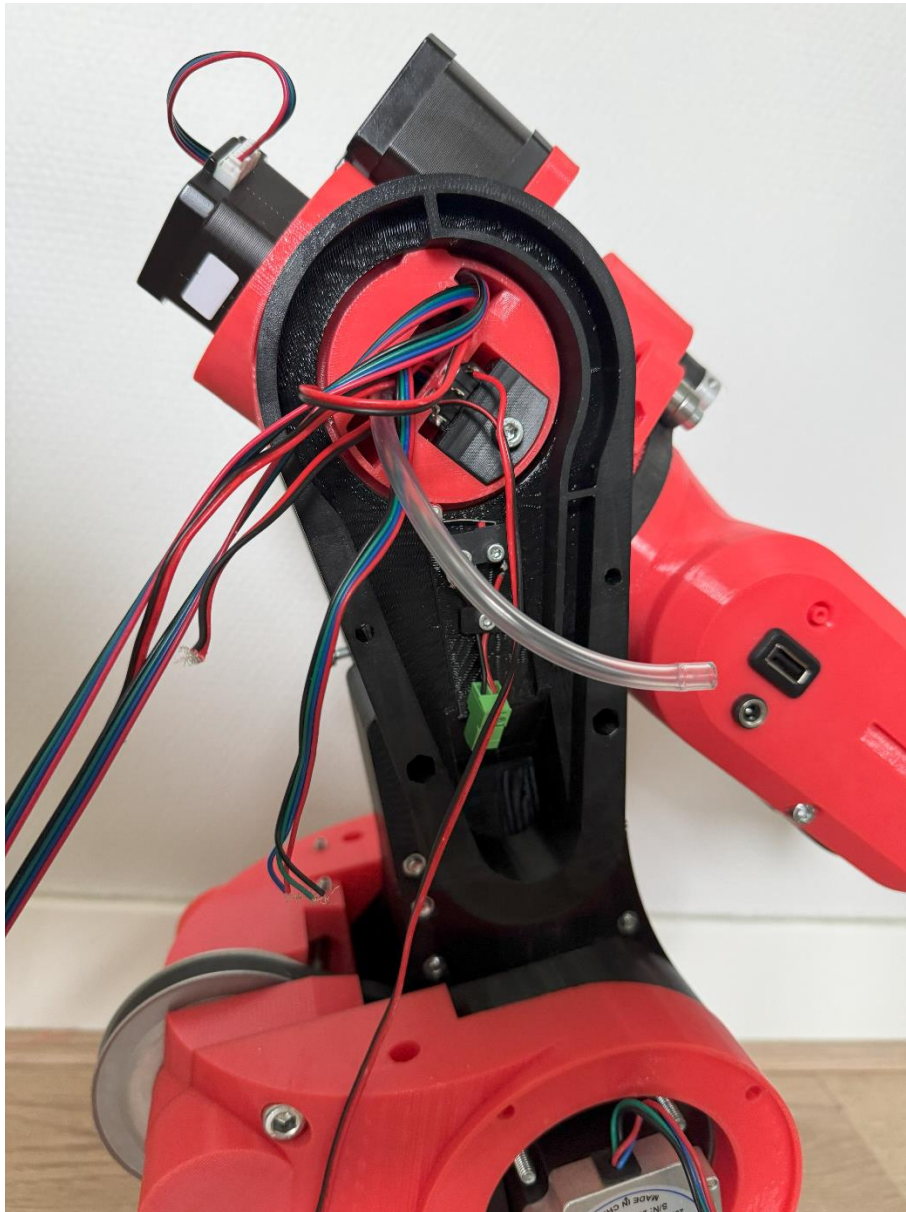

Step 61:

Items	QTY	Description
ROBOT_033	1	
BEARING_08	1	Axial bearing 50x70x5 (AXK5070 2AS)
DIN 912 M5x20	1	Hexagon socket Head Cap Screws M5x20
DIN 125 M5	1	Washer M5

Instruction:

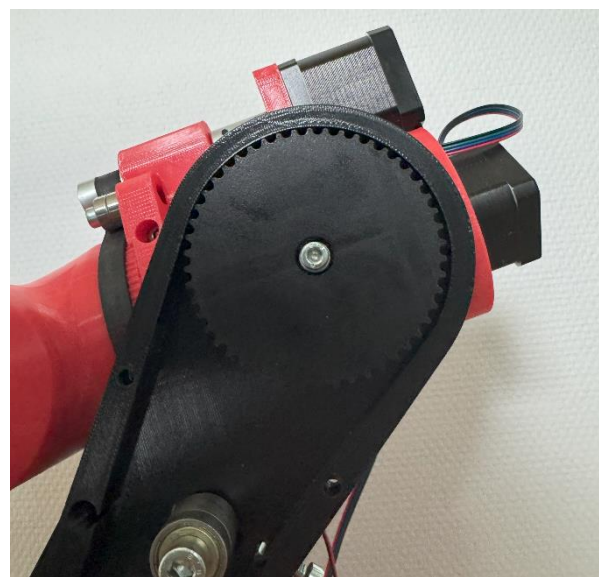

Step 62:

Items	QTY	Description
BELT_04	1	Timing belt HTD5M L435 W15
PULLEY_06	1	Pulley HTD5M 15T W15 B10

Instruction:

Install the belt and pulley, after that you can tension the belt by turning the M5 bolt, see picture.

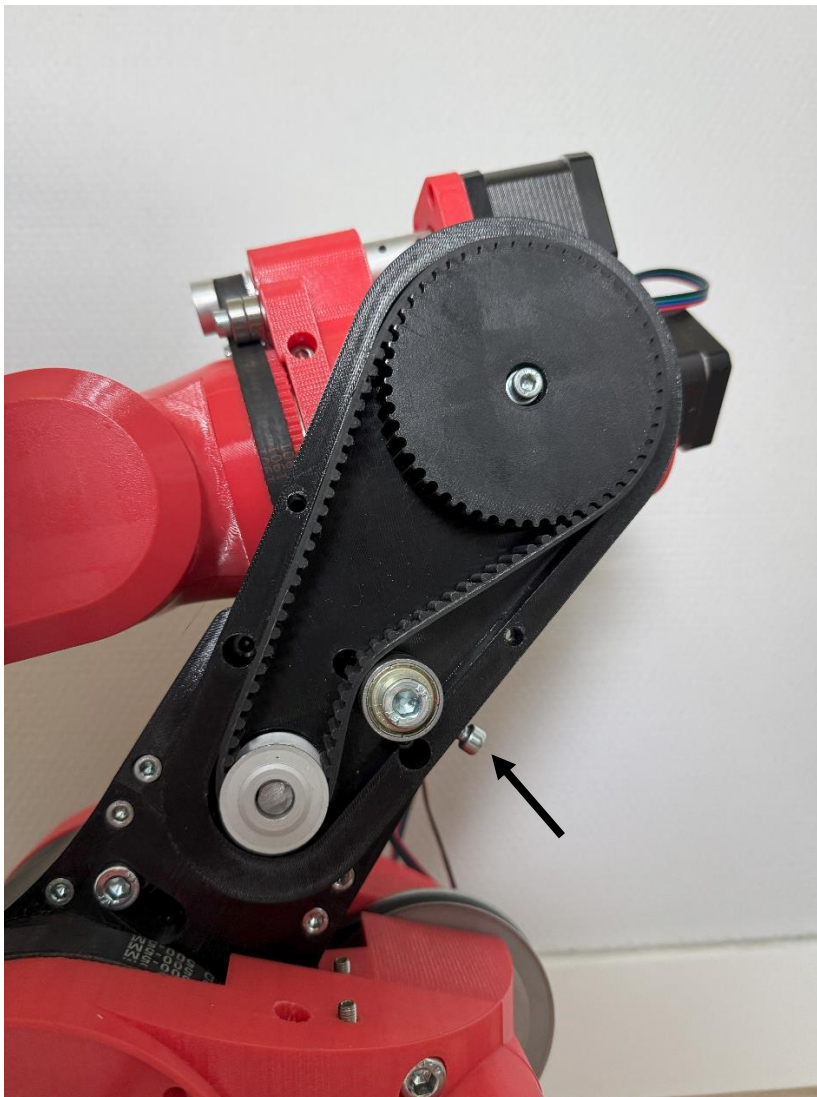

Step 63:

Items	QTY	Description
DIN 912 M5 x 20	2	Hexagon socket Head Cap Screws M5x20

Instruction:

Use the M5 x 20 bolts to tension the belt

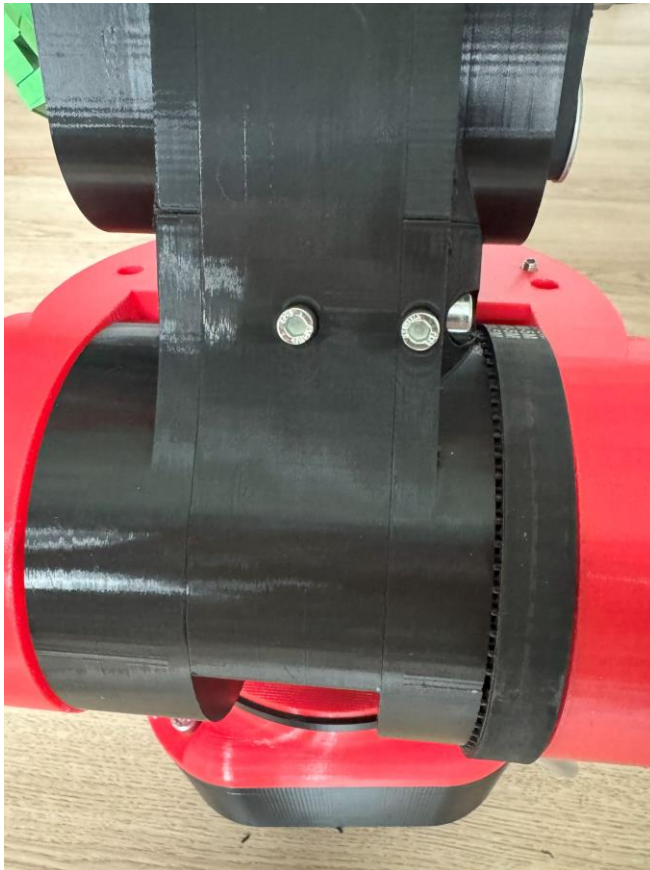

Step 64:

Items	QTY	Description
ELECTRONICS_022	1	15EDGRK 3.81 03P Male and female screw
ELECTRONICS_023	3	15EDGRK 3.81 04P Male and female screw
ELECTRONICS_024	4	15EDGRK 3.81 02P Male and female screw

Instruction:

Use connector block to connect the cables, if you are using the IO box use one more of ELECTRONICS_024. Also use ROBOT_052, for the vacuum tube.

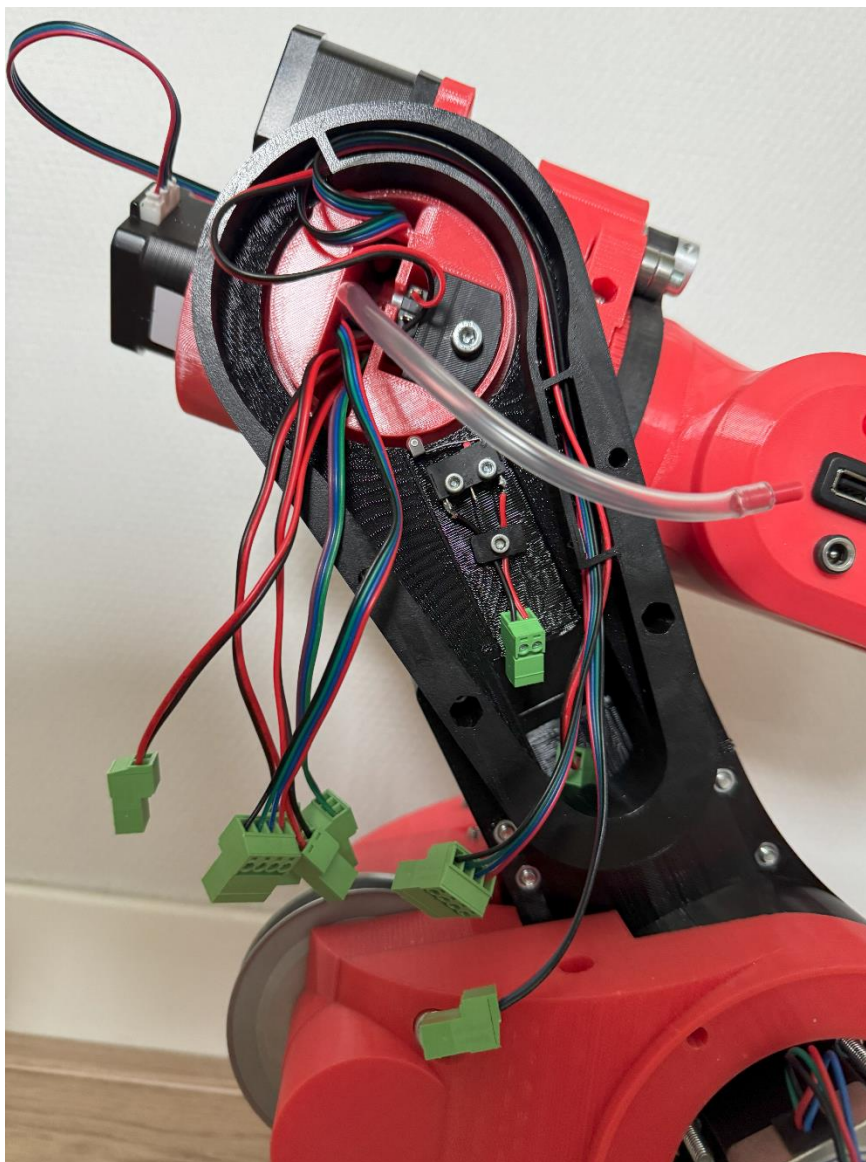

Step 65:

Items	QTY	Description
CABLE_01	2.8	Cable 2 wire, 22 AWG/ 0.34 mm ²
CABLE_02	1	3P Dupont cable male 100cm
CABLE_04	2.1	Cable 4P 22 AWG
ELECTRONICS_022	1	15EDGRK 3.81 03P Male and female screw
ELECTRONICS_023	3	15EDGRK 3.81 04P Male and female screw
ELECTRONICS_024	4	15EDGRK 3.81 02P Male and female screw

Instruction:

Cut the cable in the following sizes:

- 3 x 700 mm CABLE_04
- 4x 700 mm CABLE_01 (5x if you are using the IO box)
- 1x Vacuum tube 700 mm (if you are using the IO box)
- Shorten the 3P dupont cable at 650 mm

Next guide the cables through the robot arm as shown in the image below, use the connectors to connect the cables to each other.

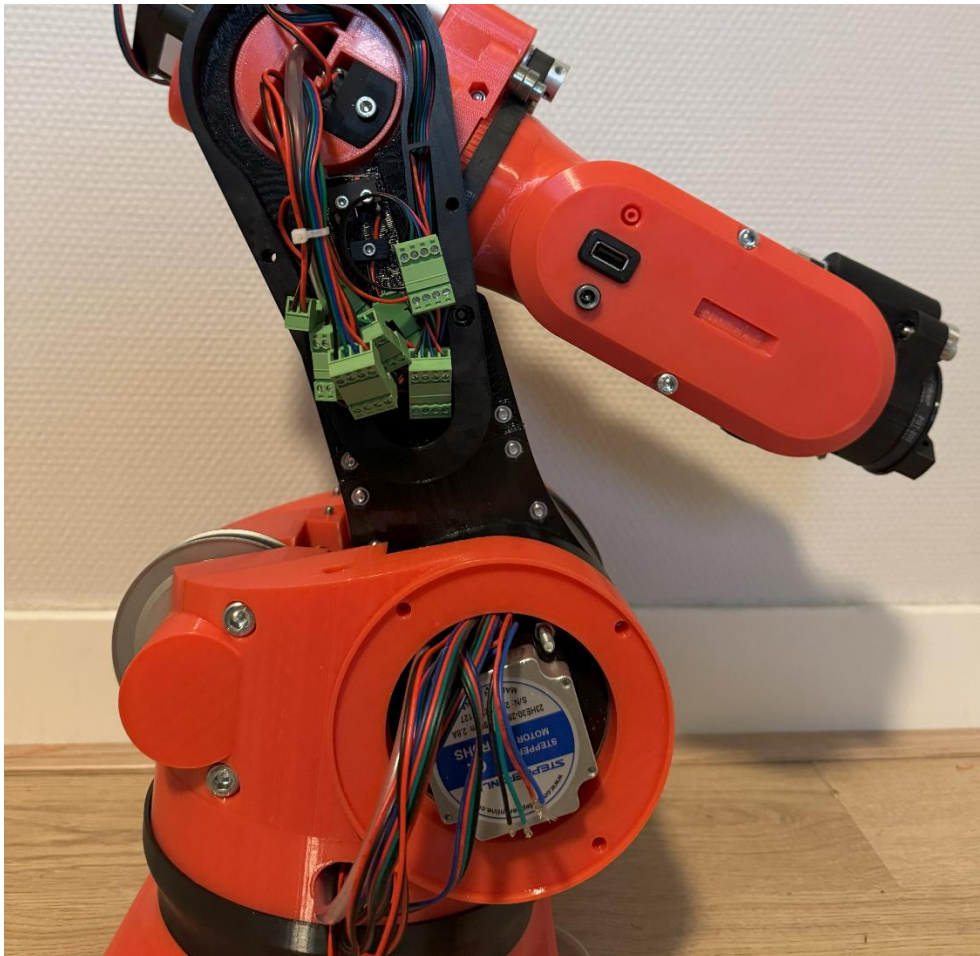

Step 66:

Items	QTY	Description
CABLE_04	0.4 m	Cable 4P 22 AWG
ELECTRONICS_023	1	15EDGRK 3.81 04P Male and female screw



Instruction:

Cut the cable in the following size:

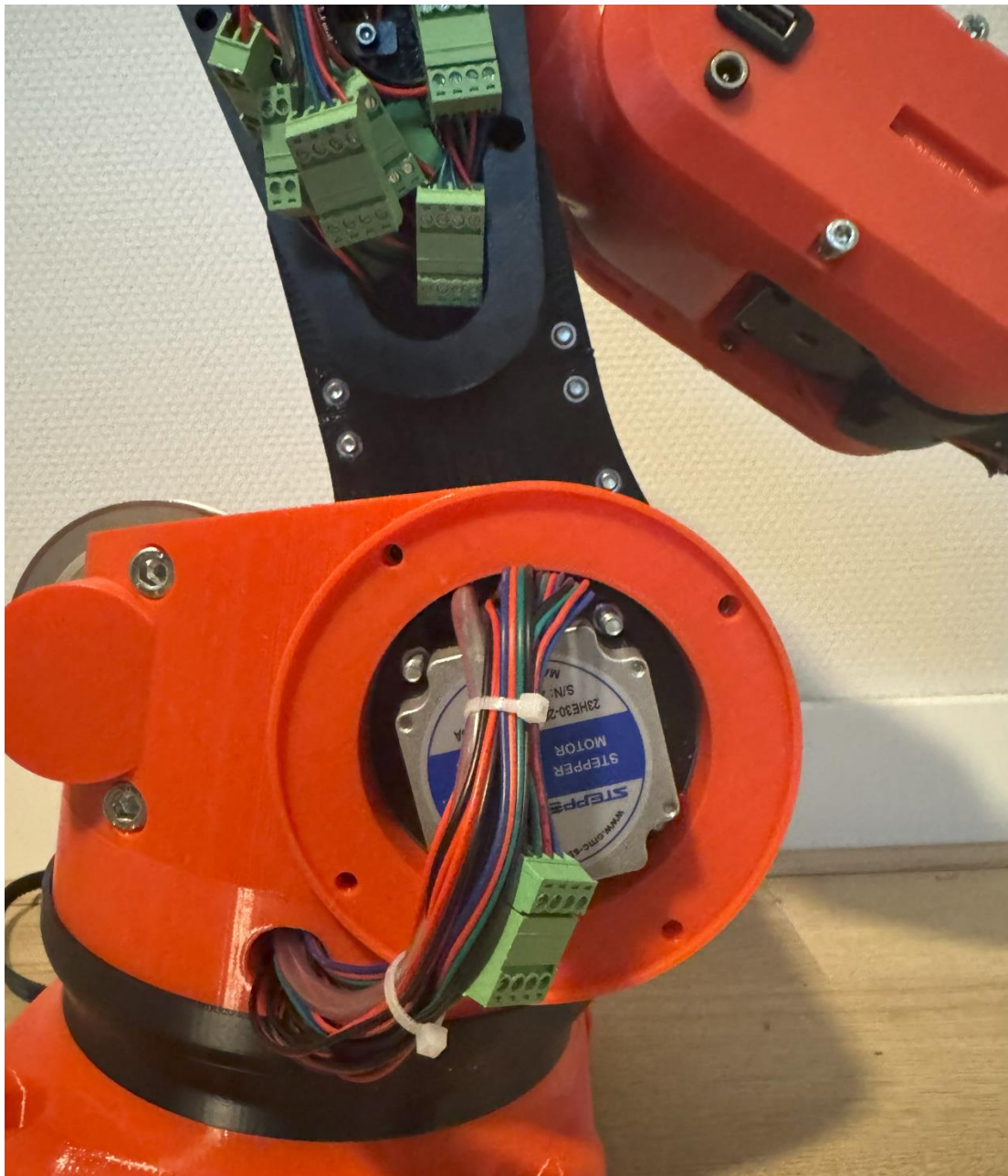
- 1 x 400 mm CABLE_04

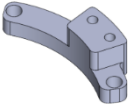

Step 67:

Items	QTY	Description	
ROBOT_030	1		
ROBOT_041	1		
ROBOT_042	1		
LIM_SWITCH_02	1		
DIN 912 M5 x 60	1	Hexagon socket Head Cap Screws M5x60	
DIN 912 M5 x 20	2	Hexagon socket Head Cap Screws M5x20	
DIN 912 M3 x 16	2	Hexagon socket Head Cap Screws M3x16	
ISO 4032 M3	2	Hexagon regular nut M3	

Instruction:

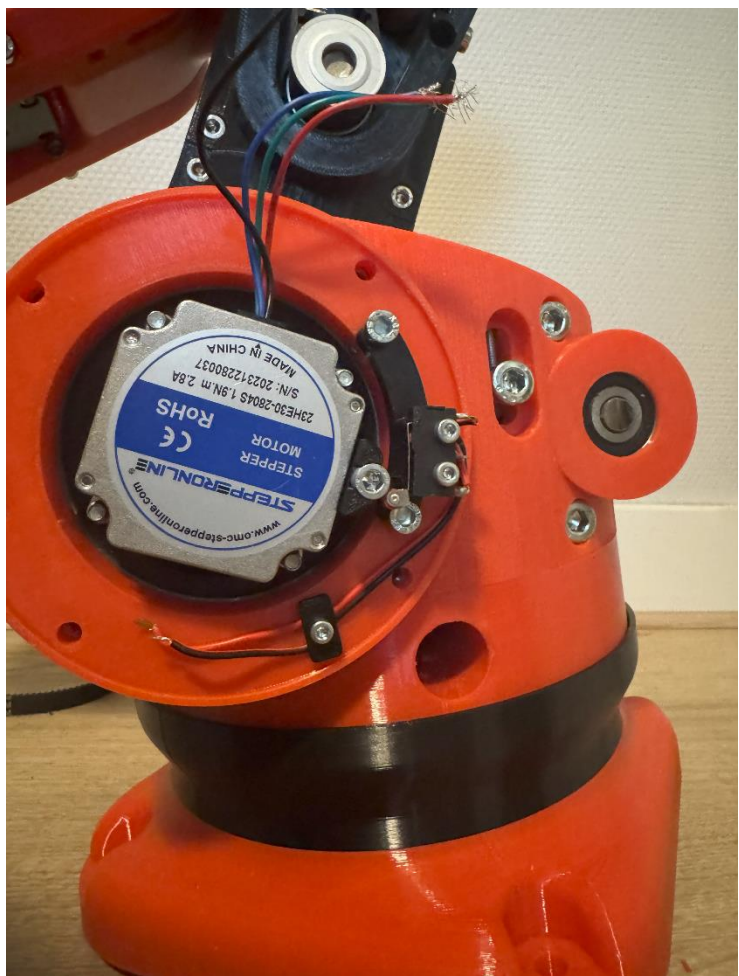
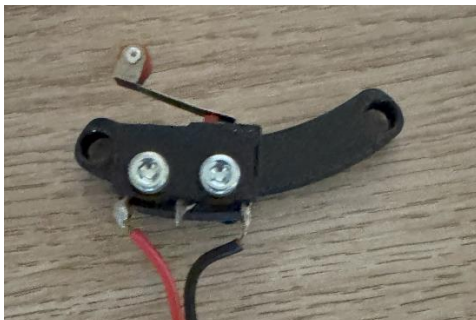

Step 68:

Items	QTY	Description
CABLE_01	0.4	Cable 2 wire, 22 AWG/ 0.34 mm2
CABLE_04	0.4	Cable 4P 22 AWG
ELECTRONICS_023	1	15EDGRK 3.81 04P Male and female screw
ELECTRONICS_024	1	15EDGRK 3.81 02P Male and female screw

Instruction:



Step 69:

Items	QTY	Description
BELT_09	1	Timing belt HTD3M L426 W10
PULLEY_07	1	Pulley HTD3M 12T W10 B6.35
BEARING_01	4	Bearing 5x14x5 (605)
DIN 912 M5 x 35	2	Hexagon socket Head Cap Screws M5x35
DIN 125 M5	2	Washer M5

Instruction:

Make sure the set screw of the pulley is facing the same direction as in the picture

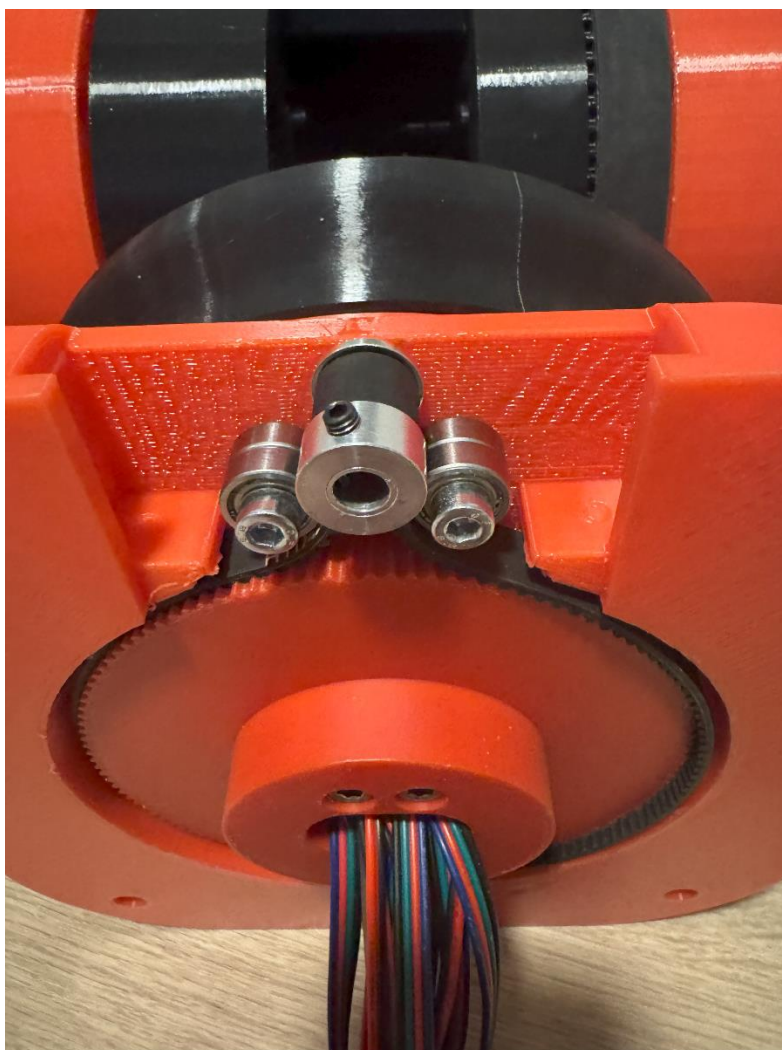

Step 70:

Items	QTY	Description
ROBOT_040	1	
DIN 912 M5 x 60	2	Hexagon socket Head Cap Screws M5x60
ISO 4032 M5	6	Hexagon regular nut M5

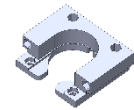

Instruction:

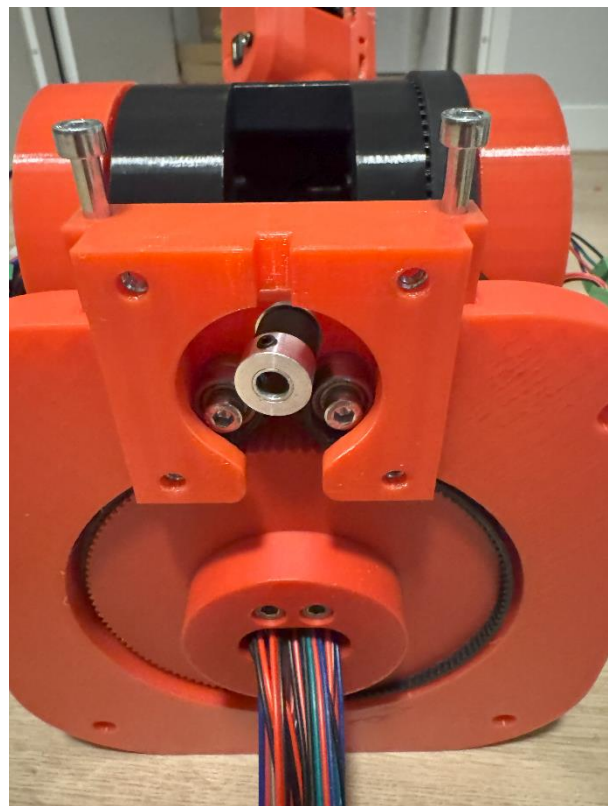

Step 71:

Items	QTY	Description
MOTOR_03	1	Stepper motor Nema23 L56
DIN 912 M5 x 20	4	Hexagon socket Head Cap Screws M5x20

Instruction:

Tighten the pulley

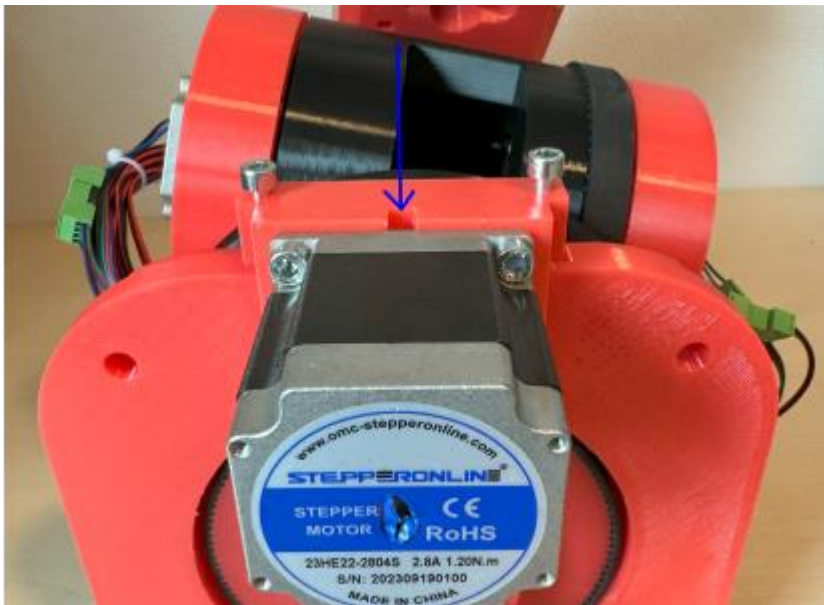

Step 72:

Items	QTY	Description
ROBOT_027	1	
DIN 6334 M8	4	Hexagon coupling nut M8
ISO 4032 M5	8	Hexagon regular nut M5
ISO 4032 M4	12	Hexagon regular nut M4
ISO 4032 M3	2	Hexagon regular nut M3

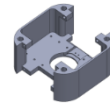

Instruction:

Insert the nuts

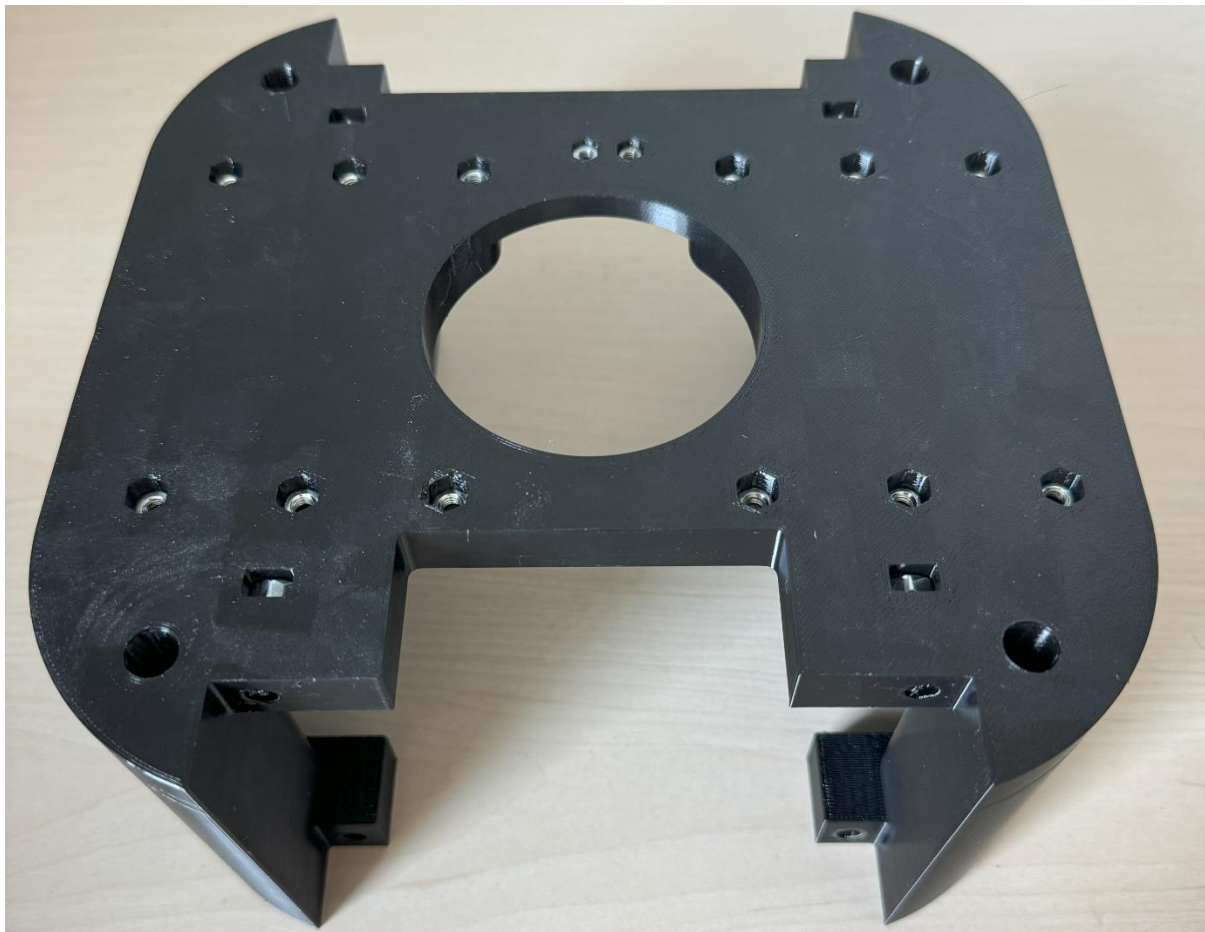

Step 73:

Items	QTY	Description
DRIVER_01	3	Stepper motor driver DM332T
DRIVER_02	3	Stepper motor driver DM320T

Instruction:

Set the stepper drivers to the following settings:

- J1: DM332T
 - Ampere: 2.55 A
 - Pulse/rev (steps/deg): 6400
- J2: DM332T
 - Ampere: 2.55 A
 - Pulse/rev (steps/deg): 6400
- J3: DM332T
 - Ampere: 2.55 A
 - Pulse/rev (steps/deg): 6400
- J4: DM320T
 - Ampere: 1.3 A
 - Pulse/rev (steps/deg): 6400
- J5: DM320T
 - Ampere: 1.3 A
 - Pulse/rev (steps/deg): 6400
- J6: DM320T
 - Ampere: 1.3 A
 - Pulse/rev (steps/deg): 6400



Step 74:

Items	QTY	Description
DIN 912 M4 x 16	12	Hexagon socket Head Cap Screws M4x16

Instruction:

Place the DRIVER_01 on the left side and DRIVER_02 on the right side

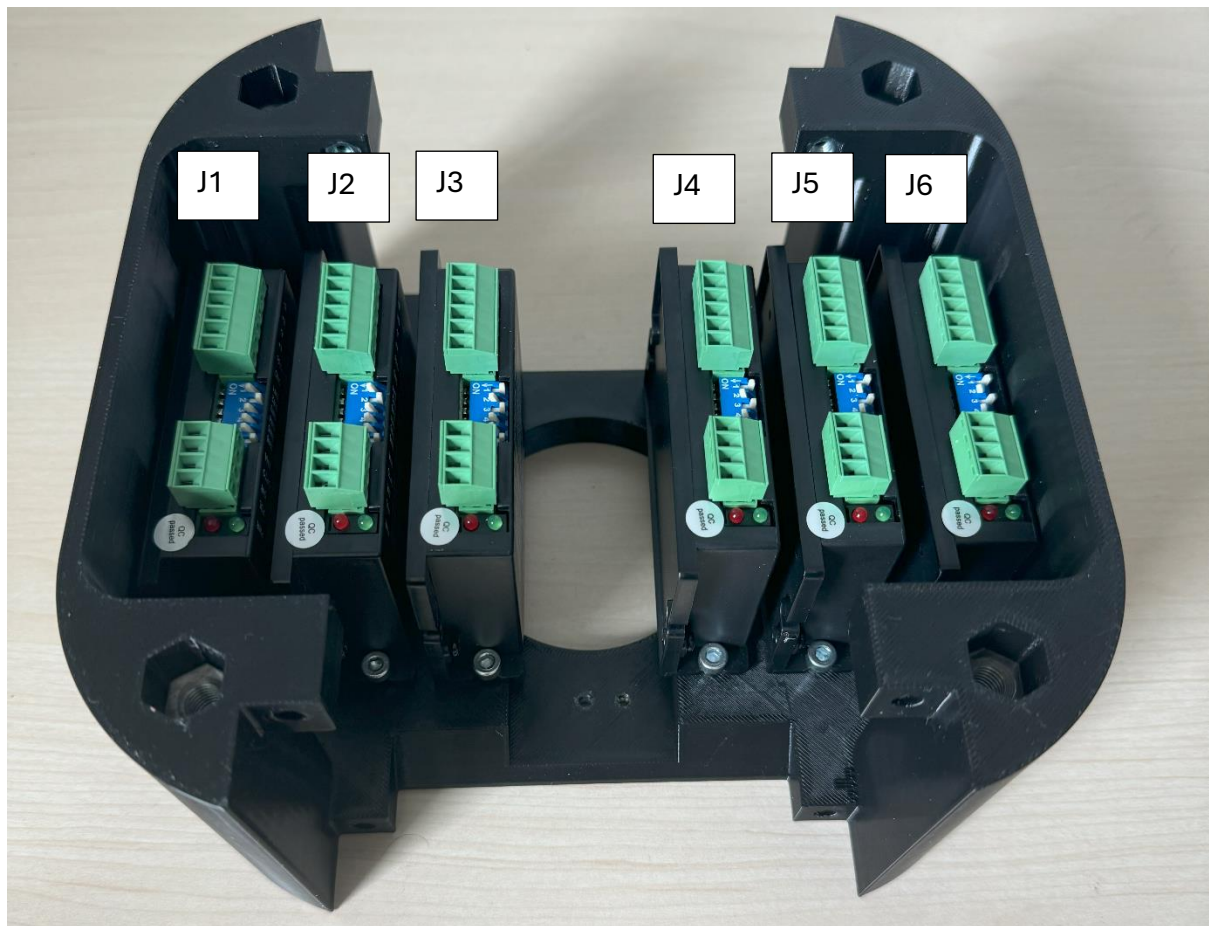

Step 75:

Items	QTY	Description
LIM_SWITCH_01	1	
DIN 912 M3 x 16	2	Hexagon socket Head Cap Screws M3x16

Instruction:

Install the limit switch as shown on the picture below

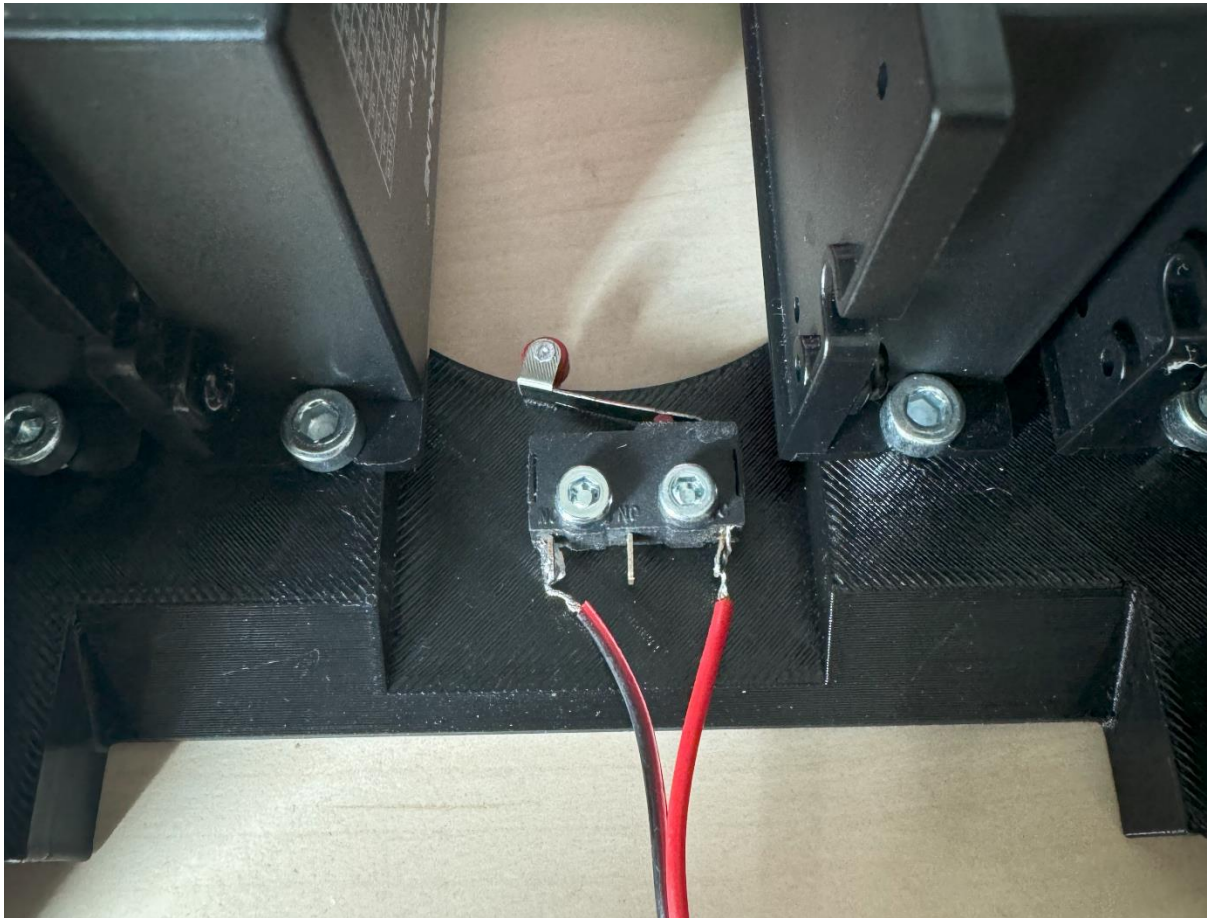

Step 76:

Items	QTY	Description
ROBOT_029	1	
ELECTRONICS_002	1	On Off switch
ELECTRONICS_005	1	5,5 x 2,1 mm jack
ELECTRONICS_025	2	Terminal FDD1.25-187, 0.5-1mm ² , 4.8x0.5
CABLE_05	±0.1 m	Cable 0,75 mm ² , 18 AWG, blue
CABLE_06	±0.1 m	Cable 0,75 mm ² , 18 AWG, white

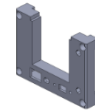

Instruction:

First make the cable the right length, 2x blue 60 mm, 1x white 90mm. at the end of the two blue wires press the terminal. Secondly solder one of the blue cable and the cable to the 5,5mm jack, the long pin is the negative side and the short pin is the positive side of the 5,5mm jack.

Negative (-) white

Positive (+) blue

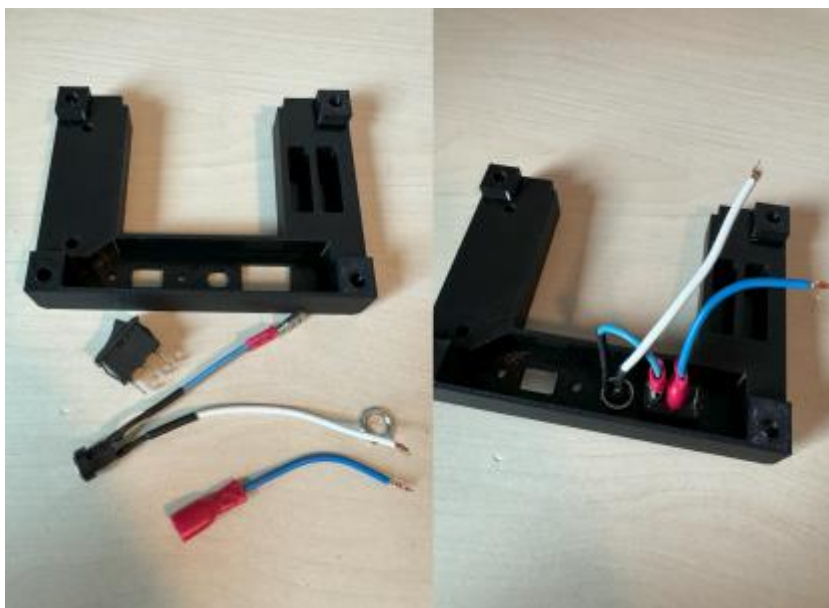

Step 77:

Items	QTY	Description
ELECTRONICS_009	1	24V to 5V DC converter
DIN 912 M4 x 16	2	Hexagon socket Head Cap Screws M4x16
ISO 4032 M4	2	Hexagon regular nut M4

Instruction:

Mount the dc converter as shown in picture below

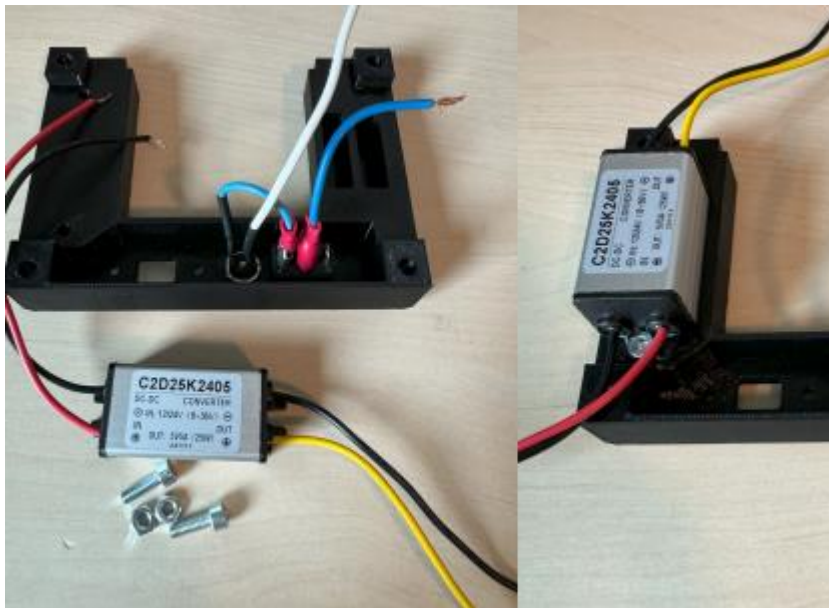

Step 78:

Items	QTY	Description
ELECTRONICS_008	1	micro usb to cable 90 degrees Down

Instruction:

Mount the usb cable as shown in the picture

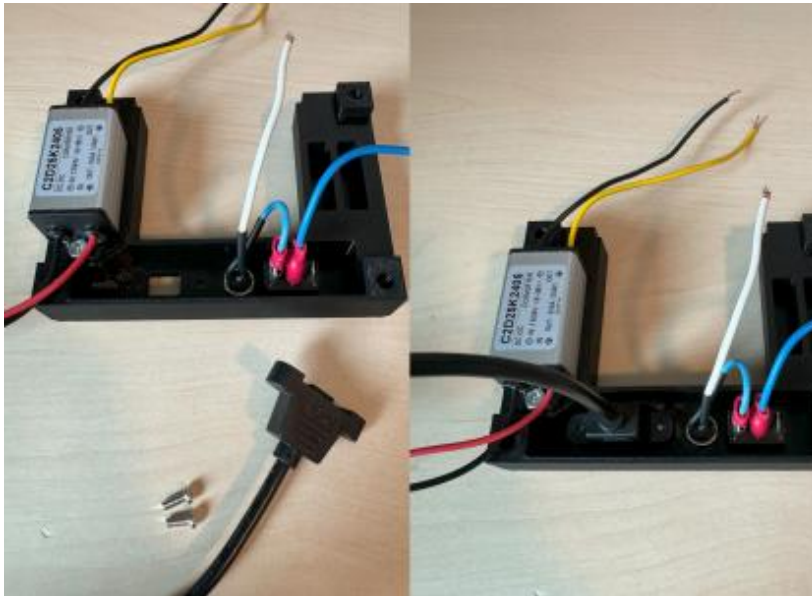

Step 79:

Items	QTY	Description
ELECTRONICS_020	2	Wago 221-415
CABLE_05	±0.4 m	Cable 0,75 mm ² , 18 AWG, blue
CABLE_06	±0.4 m	Cable 0,75 mm ² , 18 AWG, white

Instruction:

First make the cable the right length:

- 1x 250 mm blue
- 1x 250 mm white
- 1x 150 mm blue
- 1x 150 mm white

Next insert the all the cables in the Wago clamp, also the wires of the DC converter (RED + and BLACK - cable). At last insert the Wago clamp in to the 3d printed part.

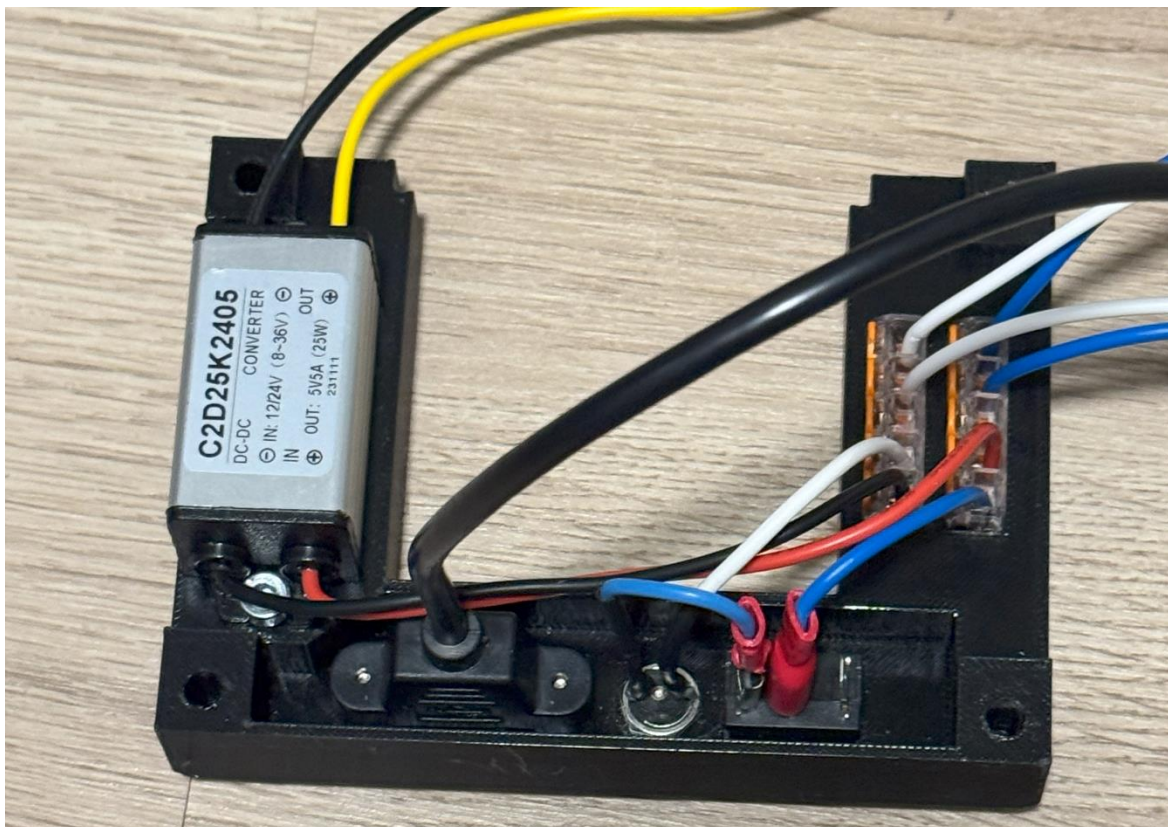

Step 80:

Items	QTY	Description
DIN 912 M5 x 35	4	Hexagon socket Head Cap Screws M5x35

Instruction:

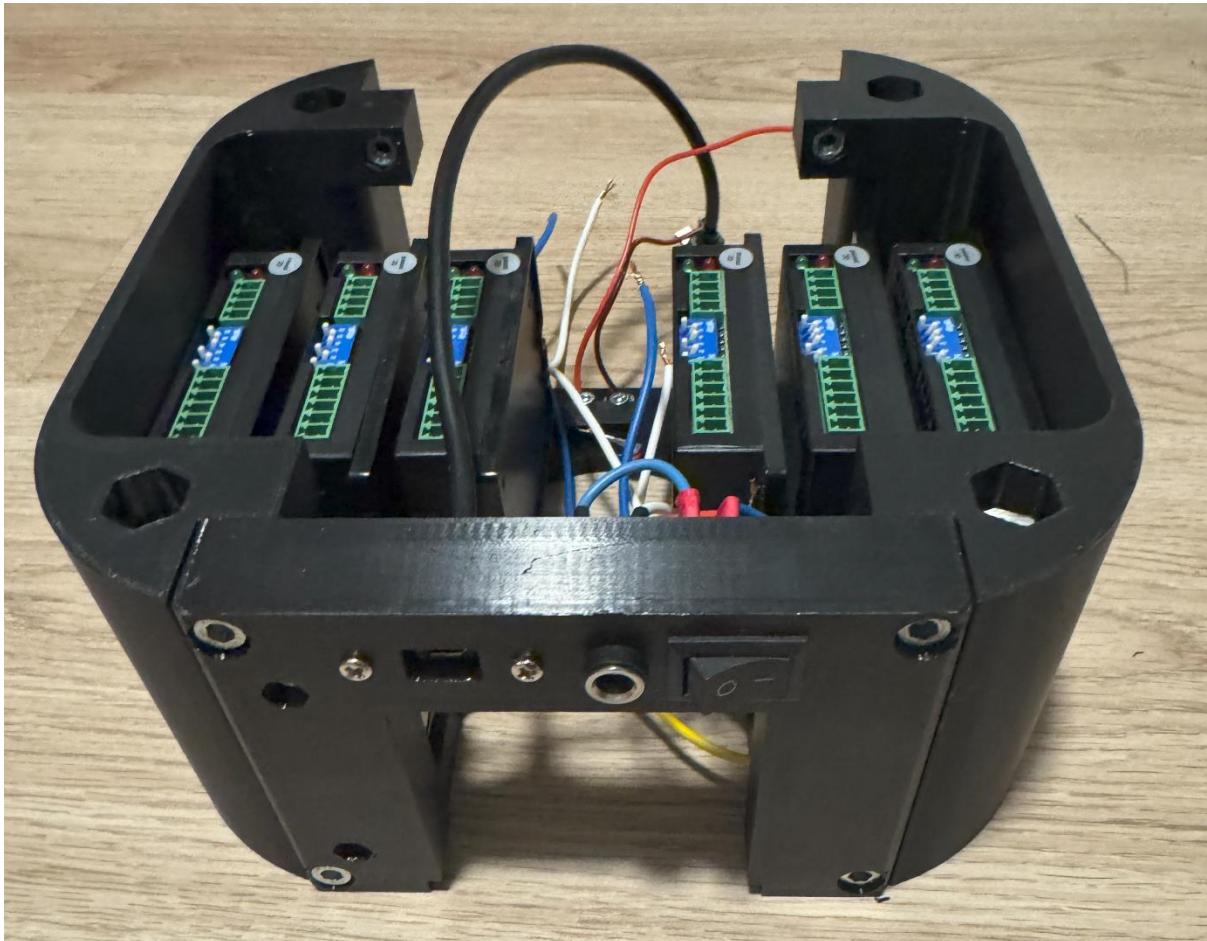

Step 81:

Items	QTY	Description
DIN 912 M8 x 80	4	Hexagon socket Head Cap Screws M8x80

Instruction:

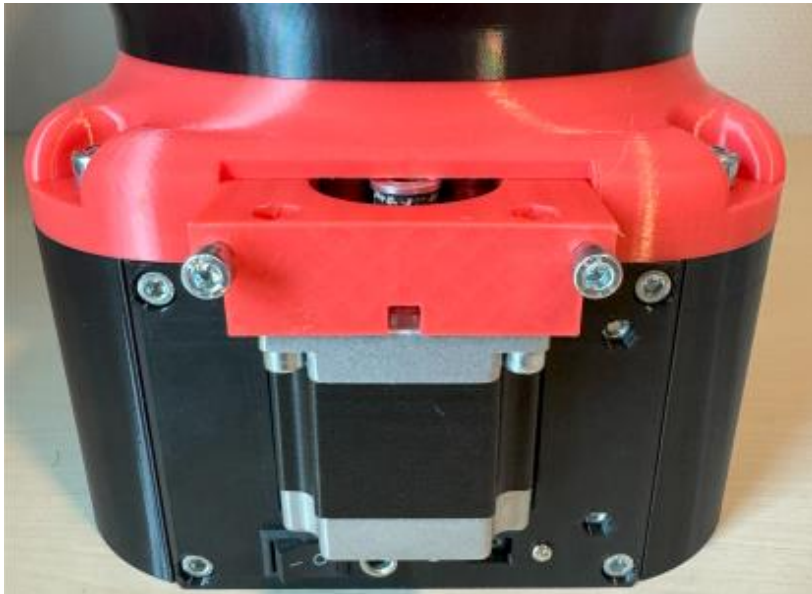

Step 82:

Items	QTY	Description
CABLE_05	±0.3 m	Cable 0,75 mm ² , 18 AWG, blue
CABLE_06	±0.3 m	Cable 0,75 mm ² , 18 AWG, white

Instruction:

First make the cable the right length:

- 4 x 70 mm blue
- 4 x 70 mm white

Next connect the power cable to the stepper drivers, at last connect the motor cables to the drivers.

Take a look at chapter 5, Schematics and wiring

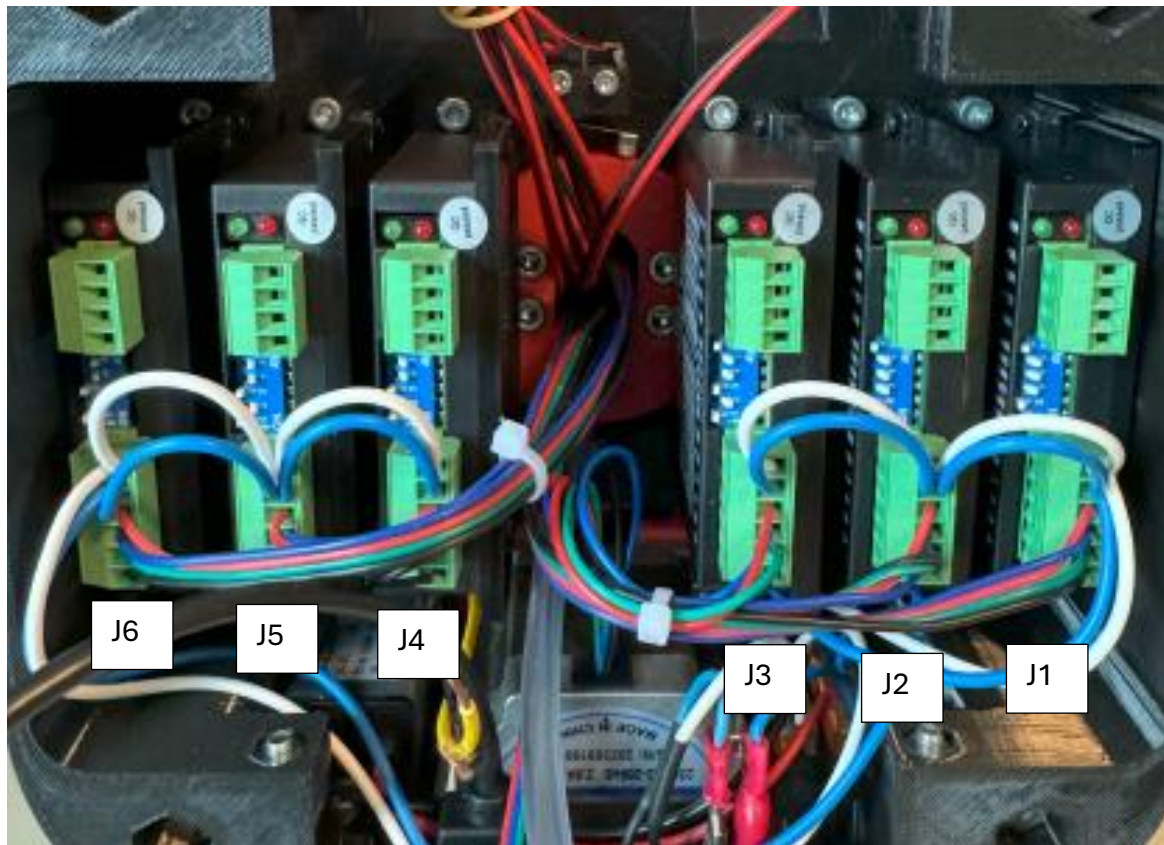

Step 83:

Items	QTY	Description
ELECTRONICS_021	1	Wago 221-2411
ELECTRONICS_003	1	Breakout board esp32
ELECTRONICS_004	2	ESP32 38 pin

Instruction:

Bind all the black cables of the limit switches together as shown in the picture below. You can make the black cables a bit shorter than the red cable ± 75 mm. on the other end of the Wago clamp put one black cable with a length of ± 75 mm.

At last connect the wires of the limit switches to the ESP32 breakout board



Step 84:

Items	QTY	Description
CABLE_04	1	Cable 4P 22 awg

Instruction:

Use CABLE_04 for wiring the stepper drivers to the ESP32, look for wiring instructions in chapter 5

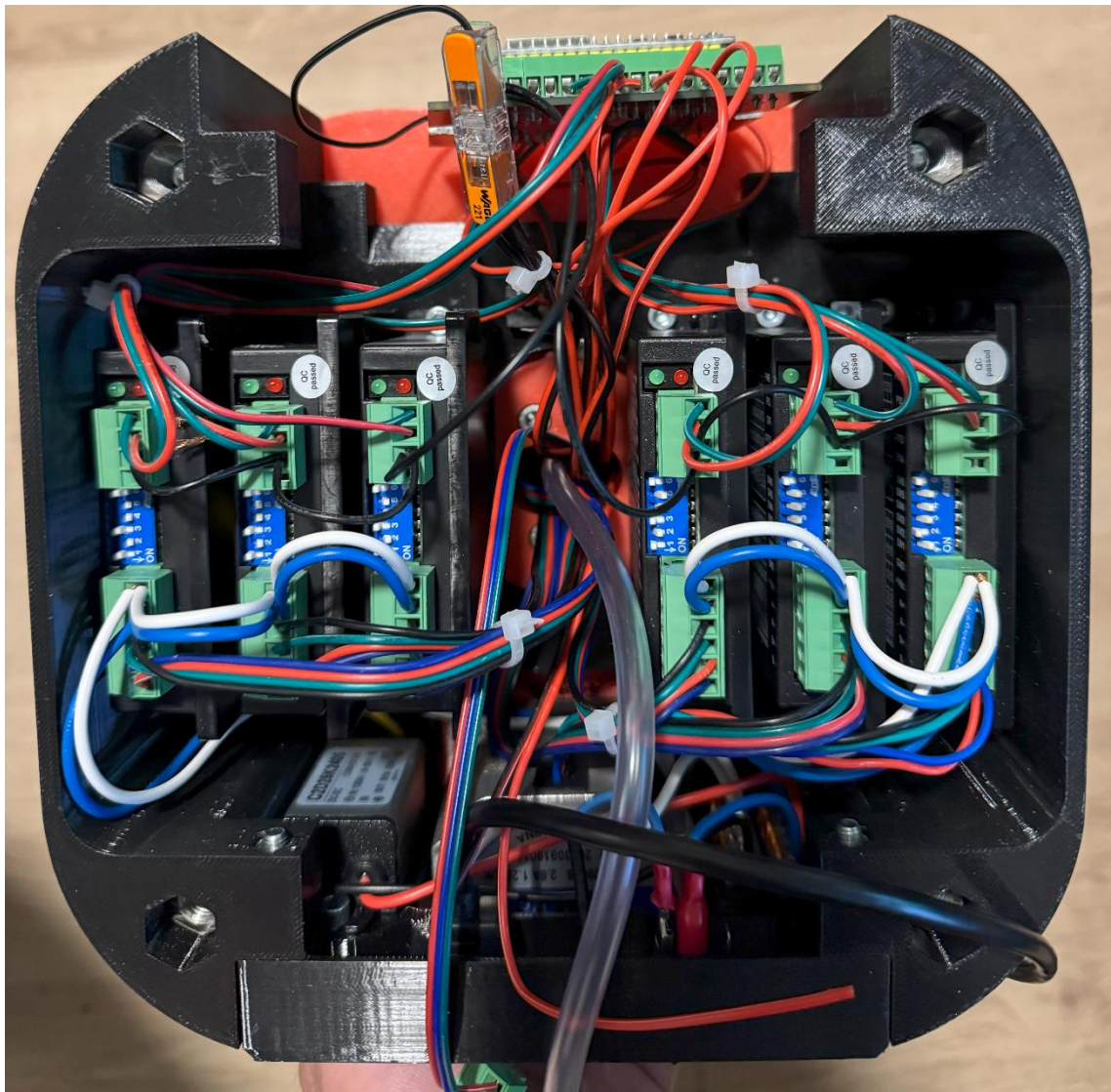

Step 85:

Items	QTY	Description
ELECTRONICS_022	1	15EDGRK 3.81 03P Male and female screw

Instruction:

Skip this step if you are using the IO box, go to **Step 86**

In this step the 3P dupont cable will be connected to the 5V converter and the ESP32 board, for wiring instructions please check chapter 5

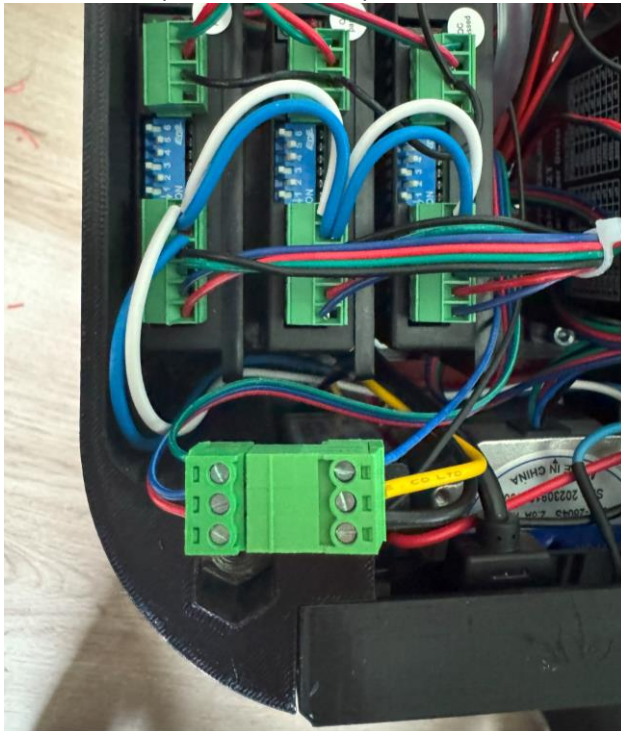

Step 86:

Items	QTY	Description
ELECTRONICS_022	1	15EDGRK 3.81 03P Male and female screw

Instruction:

Do this step only if you are using a IO box

Connect the male side of the 03P connector to the servo cable. Use the 02P male connector part of the IO box, to the + and – cables of the 5V converter.

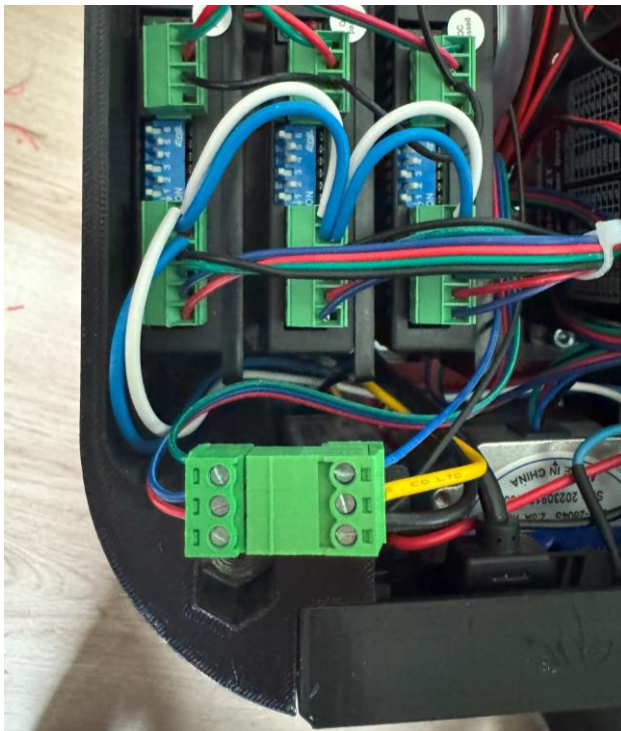



Step 87:

Items	QTY	Description
-------	-----	-------------

Instruction:

This step is only necessary if you are using the IO box. Connect 02P male connector to the black and red wire that is connected to the 5.5 mm jack, of step 30.

Step 88:

Items	QTY	Description
ROBOT_032	1	
ROBOT_048	1	
DIN 912 M3 x 16	2	Hexagon socket Head Cap Screws M3x16
ISO 4032 M3	2	Hexagon regular nut M3

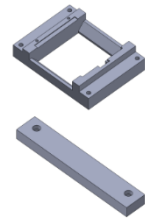

Instruction:



Step 89:

Items	QTY	Description
DIN 912 M5 x 35	4	Hexagon socket Head Cap Screws M5x35

Instruction:



Step 90:

Items	QTY	Description
ROBOT_049	1	

Instruction:

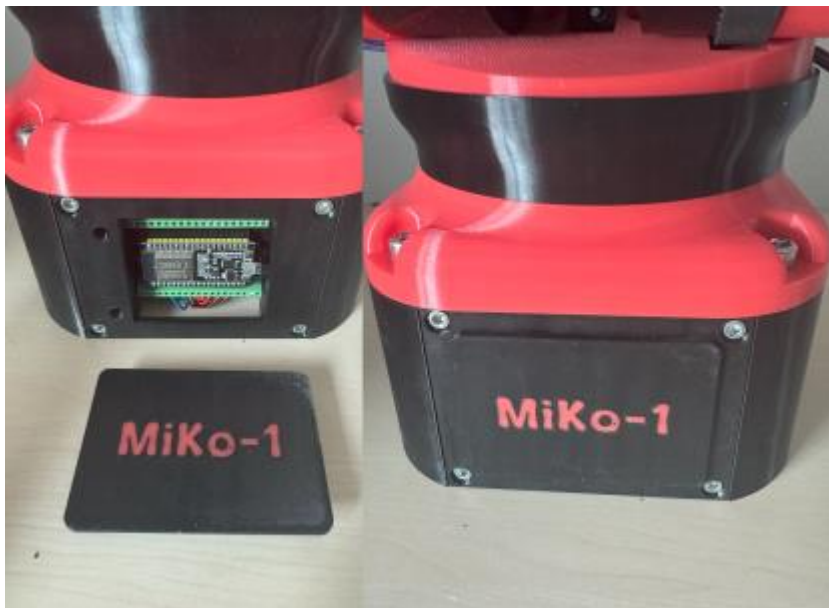

Step 91:

Items	QTY	Description
ROBOT_034	1	
ROBOT_043	1	
DIN 912 M5 x 35	8	Hexagon socket Head Cap Screws M5x35

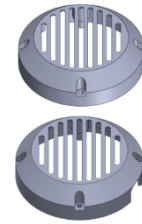

Instruction:



Step 92:

Items	QTY	Description
ROBOT_021	1	
DIN 912 M5 x 20	2	Hexagon socket Head Cap Screws M5x20



Instruction:



Step 93:

Items	QTY	Description
ROBOT_045	1	
DIN 912 M5 x 35	2	Hexagon socket Head Cap Screws M5x35

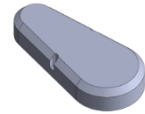

Instruction:



Step 94:

Items	QTY	Description
ROBOT_053	4	
DIN 912 M8 x 45	4	Hexagon socket Head Cap Screws M8x45

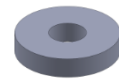

Instruction:

Use the M8 x 45 bolt to mount the robot arm to a platform or table, if the bolt are too long you can use ROBOT_053 as spacer.

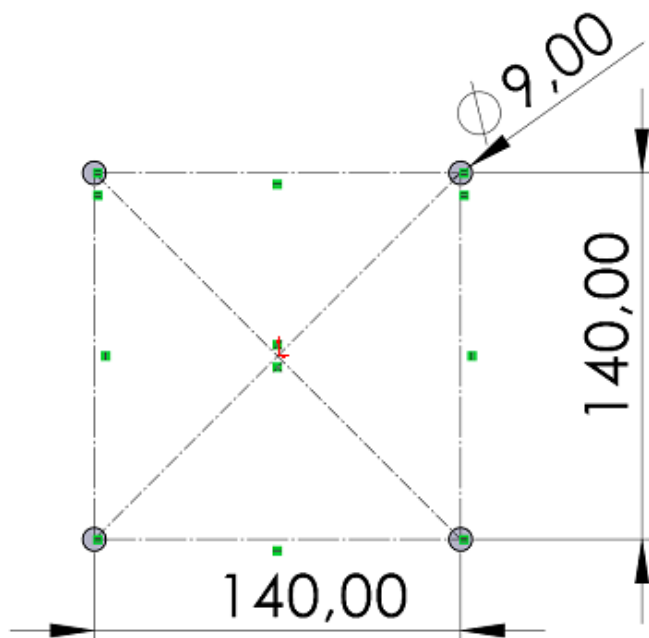



8: Firmware installation

For the installation of the firmware please visit the following page,

<https://mikobots.com/mikobots-studio/help/installation/installation-firmware-esp32/>.



9: Software setup

For Information on how to setup MiKo-1 in MiKoBots Studio please visit the following page, <https://mikobots.com/mikobots-studio/help/robot-setup/miko-1/>.



9: Appendix

In the appendix you can find the following documents.

- Axis
- Schematic of MiKo-1
- Limit switch with cables
- Breakout board

Ø 8

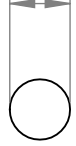

40

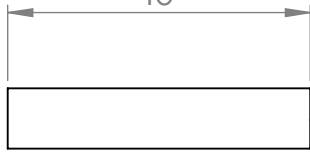

← AXIS_06

Ø 8

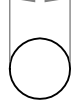

65

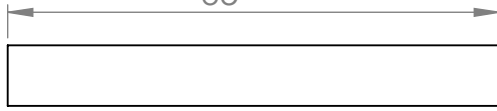

← AXIS_01

Ø 8

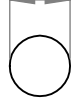

85

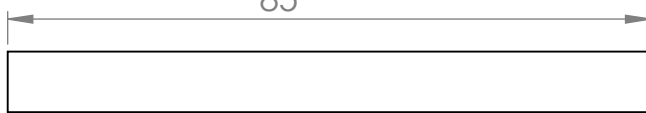

← AXIS_02

Ø 8

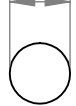

145

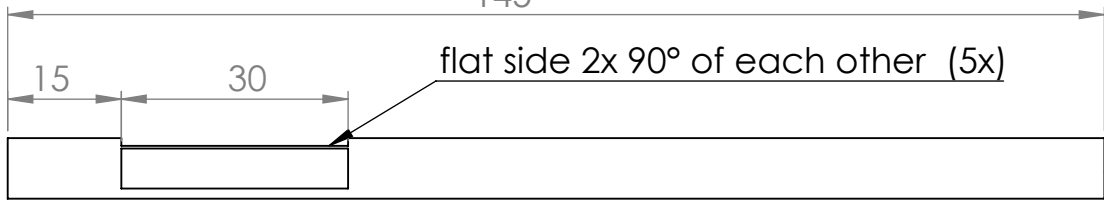

← AXIS_04

Ø 10



70

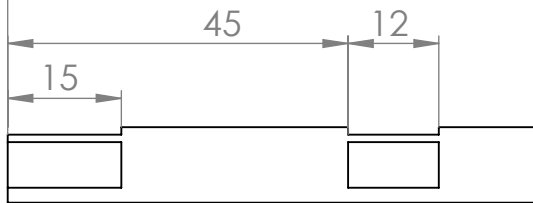

← AXIS_05

Ø 10



132

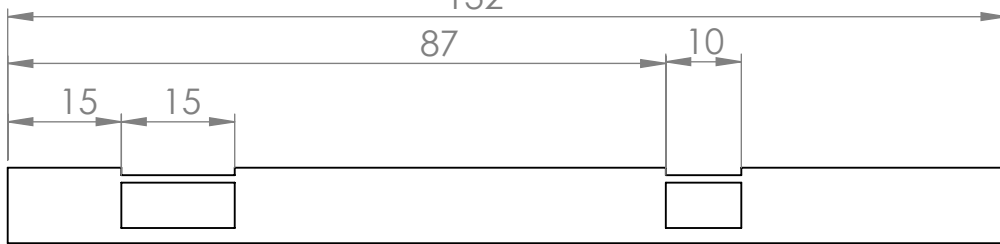

← AXIS_03



TOLERANCE :	GENERAL TOLERANCE ACCORDING TO:	ISO 2768 T1: m
		ISO 2768 T2: m
DISCRIPTION:		
SCALE: 1:1	UNIT OF MEASURE : MM	Sheet 1 of 1
FORMAT : A4	DRAWING NR. : Axis	REV: 000
MASS (g) : 32.06	MATERIAL :	
GET. :	DATE :	

0 MM

100 MM

6 x: ELECTRONICS_001 (Micro Limit Switch (Roller Lever))
 2000 mm: CABLE_01 (red black cable, awg22 / 0.5 mm²)

Drill the holes to Ø3 mm

Switch 1



Wire length:
150 mm

Switch 2



Wire length:
120 mm

Switch 3



Wire length:
50 mm

Switch 4



Wire length:
360 mm

Switch 5



Wire length:
400 mm

Switch 6



Wire length:
550 mm

 MiKoBots www.mikobots.com	TOLERANCE :	GENERAL TOLERANCE ACCORDING TO:	ISO 2768 T1: m
			ISO 2768 T2: m
	DISCRIPTION:	Micro Limit Switch (Roller Lever)	
SCALE: 1:1	UNIT OF MEASURE : MM	Sheet 1 of 1	
MASS (g) : 1.31	MATERIAL : Material <not specified>	FORMAT :	DRAWING NR. :
GET. :	DATE :	A4	ELECTRONICS_001
			001

0 MM

100 MM

GPIO	Comment	Robot
GPIO1		
GPIO2		SWITCH 6
GPIO3		
GPIO4		PUL 1
GPIO5		DIR 2
GPIO6		
GPIO7		
GPIO8		
GPIO9		
GPIO10		
GPIO11		
GPIO12		SWITCH 1
GPIO13		SWITCH 2
GPIO14		SWITCH 3
GPIO15		SERVO
GPIO16		DIR 1
GPIO17		PUL 2
GPIO18		PUL 3
GPIO19		DIR 3
GPIO20		
GPIO21		PUL 6
GPIO22		DIR 6
GPIO23		SWITCH 4
GPIO24		
GPIO25		PUL4
GPIO26		DIR 4
GPIO27		SWITCH 5
GPIO28		
GPIO29		
GPIO30		
GPIO31		
GPIO32		PUL 5
GPIO33		DIR 5
GPIO34		
GPIO35		
GPIO36		
GPIO37		
GPIO38		

Color code motors				
Motor	A+	A-	B+	B-
Nema 23 L56 - J1	Black	Green	Red	Blue
Nema 23 L76 - J2,3	Black	Green	Red	Blue
Nema 17 L45 - J4	Black	Blue	Green	Red
Nema 17 L45 - J4	Black	Blue	Green	Red

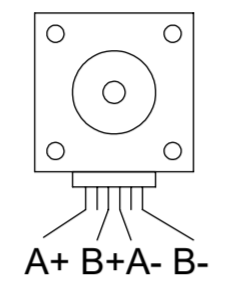

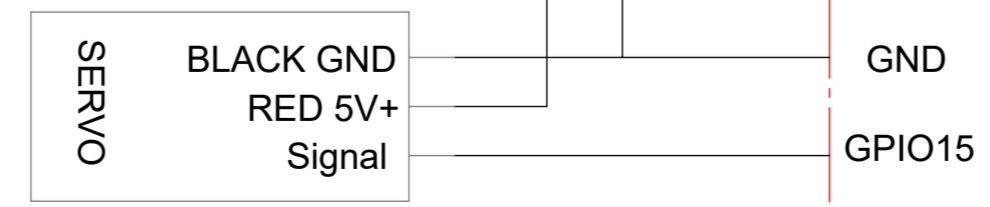
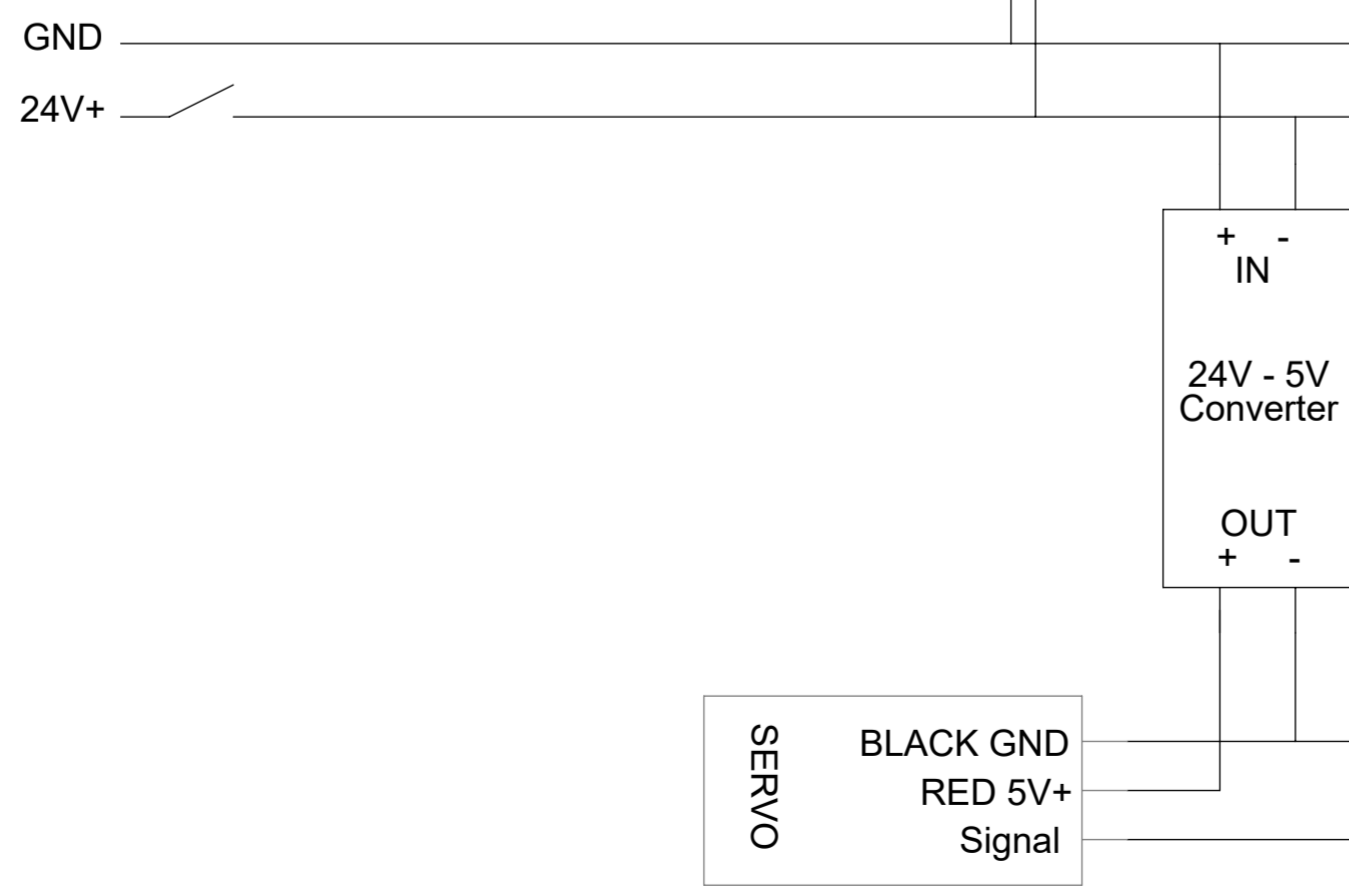
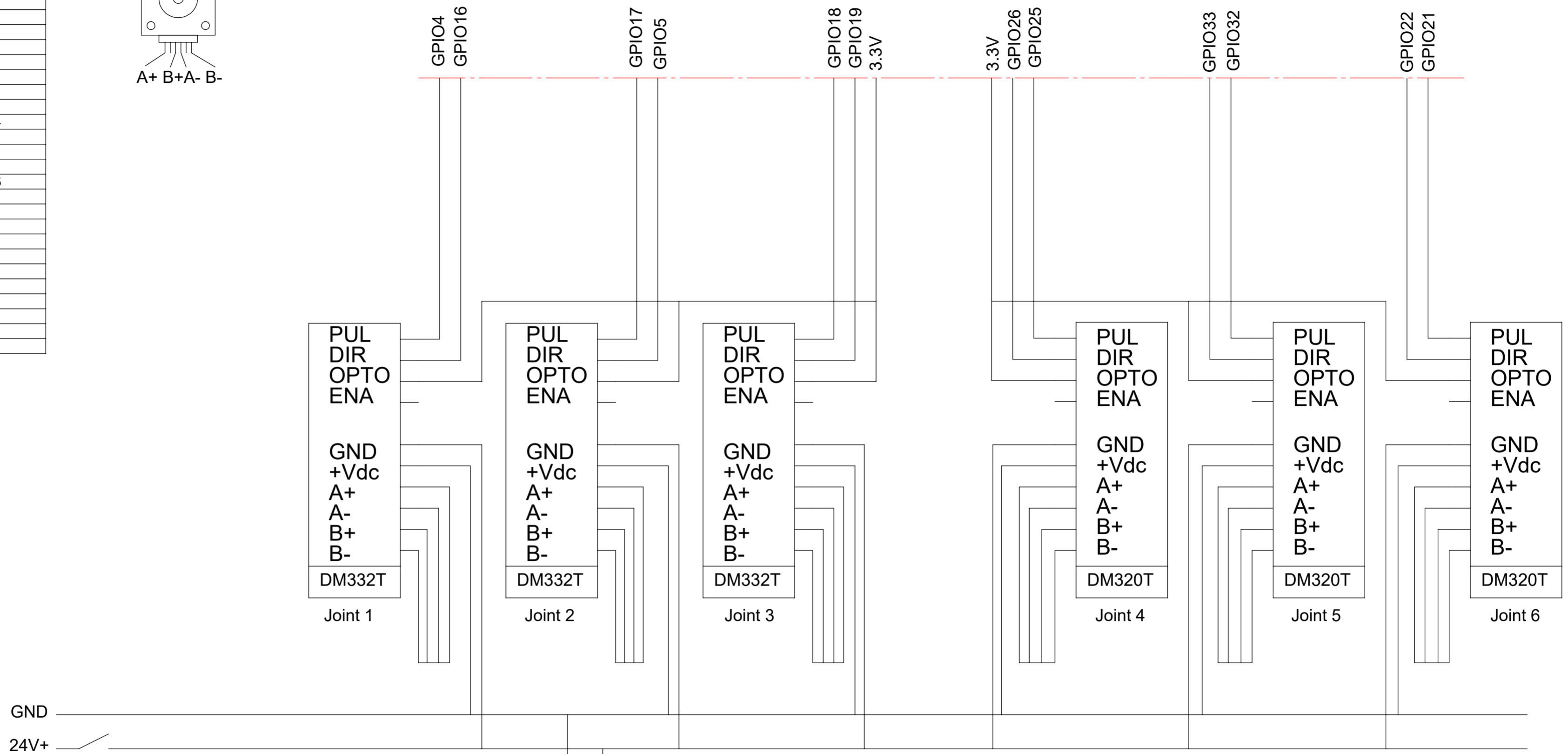
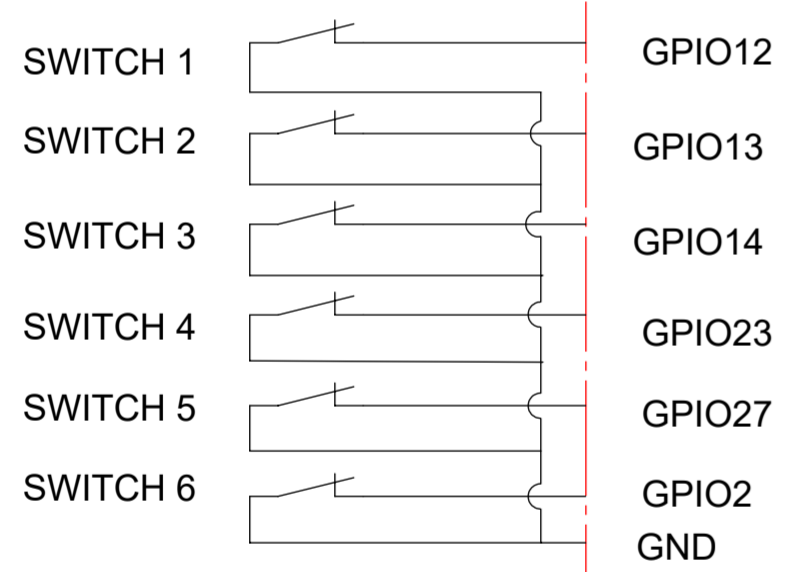

ESP 32

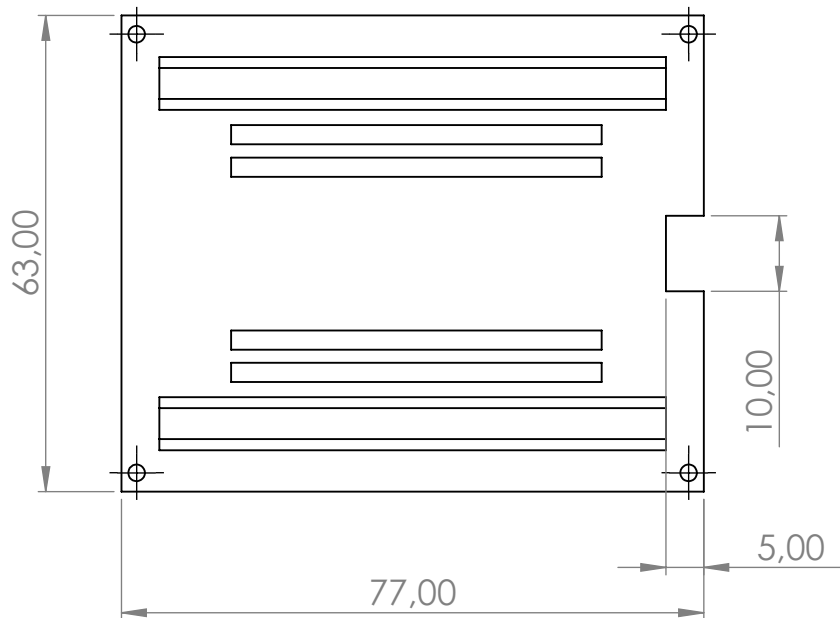

MiKoBots
www.mikobots.com

TOLERANCE :	Algemene toleranties volgens ISO 2768-2	TOL. CLASS : m
	Vormtoleranties volgens ISO 2768-1	TOL. CLASS : m
DISCRIPTION: Schematic MiKo-1		
SCALE: 1:2	UNIT OF MEASURE: MM	Sheet 1 of 1
FORMAT: A2	DRAWING NR.: Schematic	REV: 001



 MiKoBots www.mikobots.com	TOLERANCE :	GENERAL TOLERANCE ACCORDING TO:	ISO 2768 T1: m
			ISO 2768 T2: m
	DISCRIPTION: Breakout board esp32		
MASS (g) :	MATERIAL :	SCALE: 1:1	UNIT OF MEASURE : MM
GET. :	DATE :	FORMAT : A4	DRAWING NR. : ELECTRONICS_003
			Sheet 1 of 1
			REV: 000

0 MM

100 MM